

Disegni dell'ordine architettonico

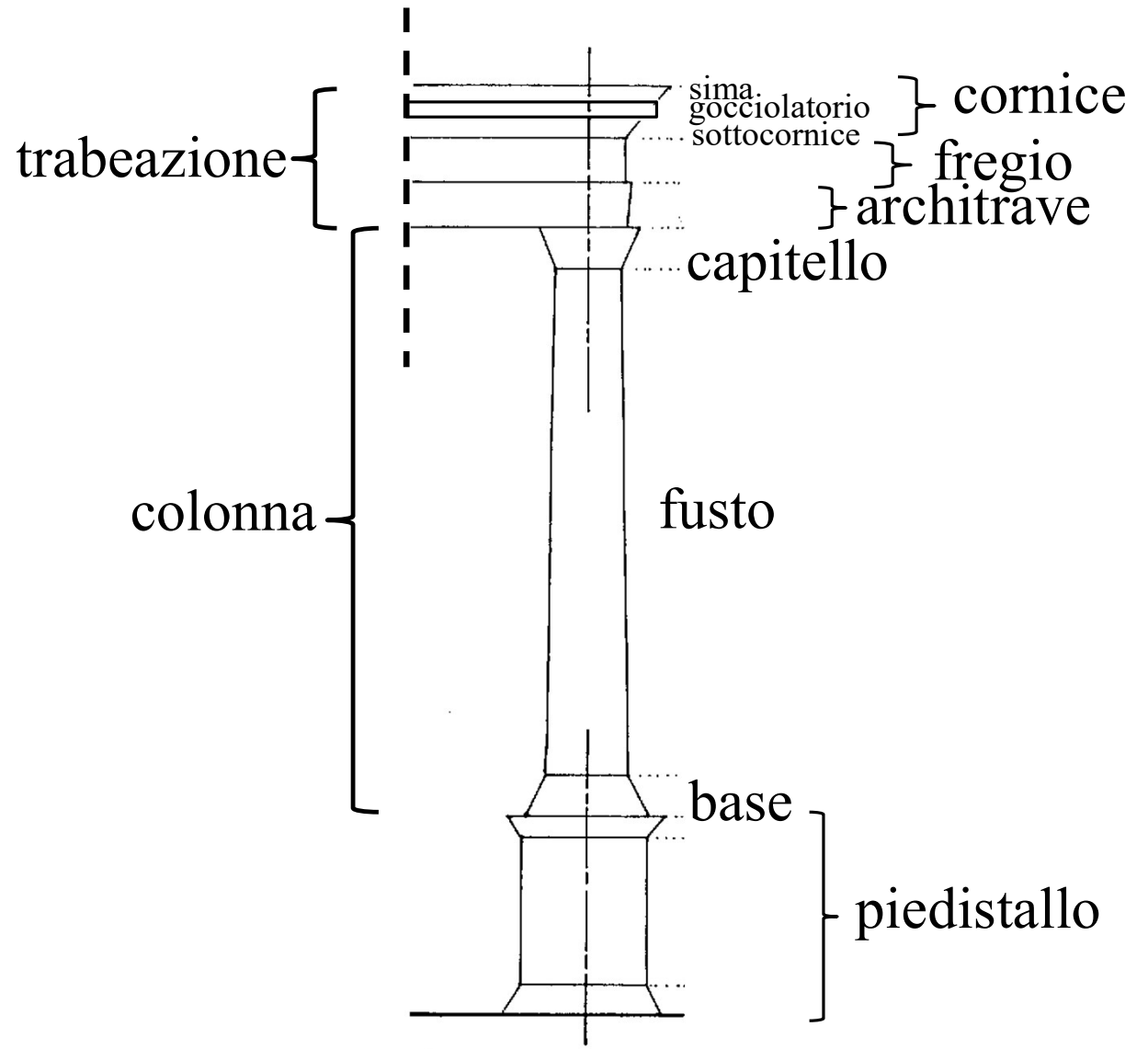

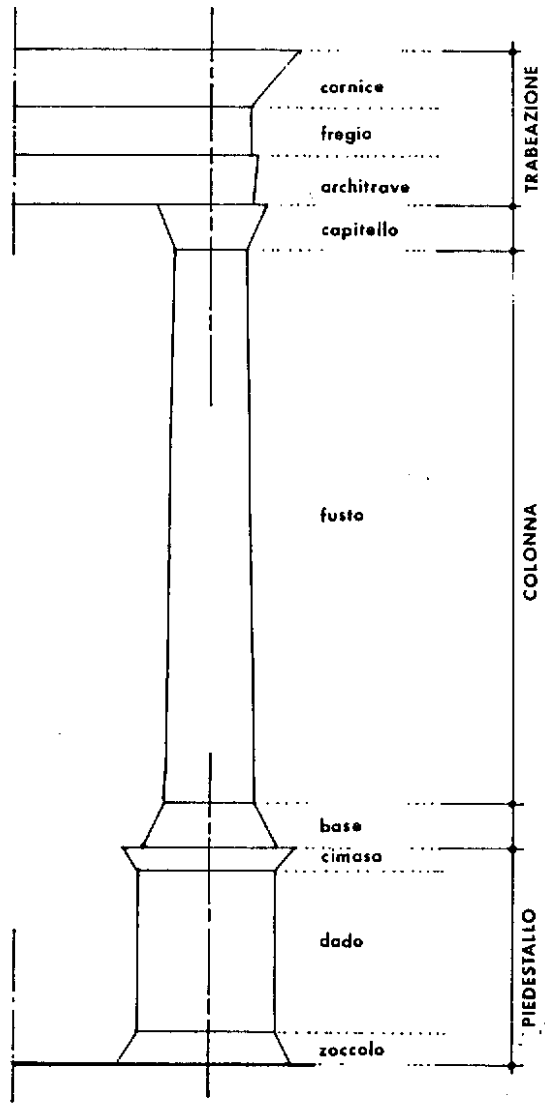

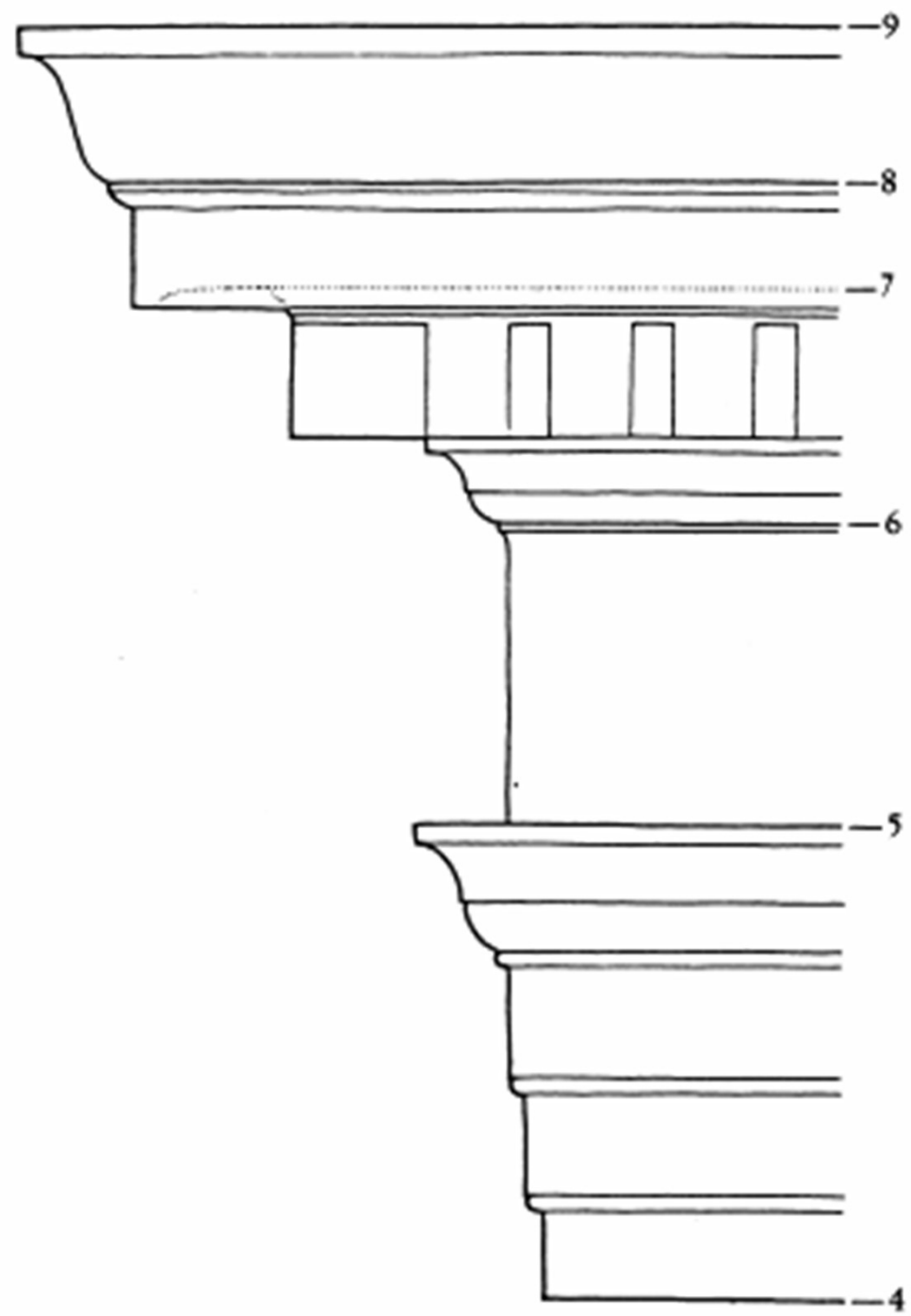
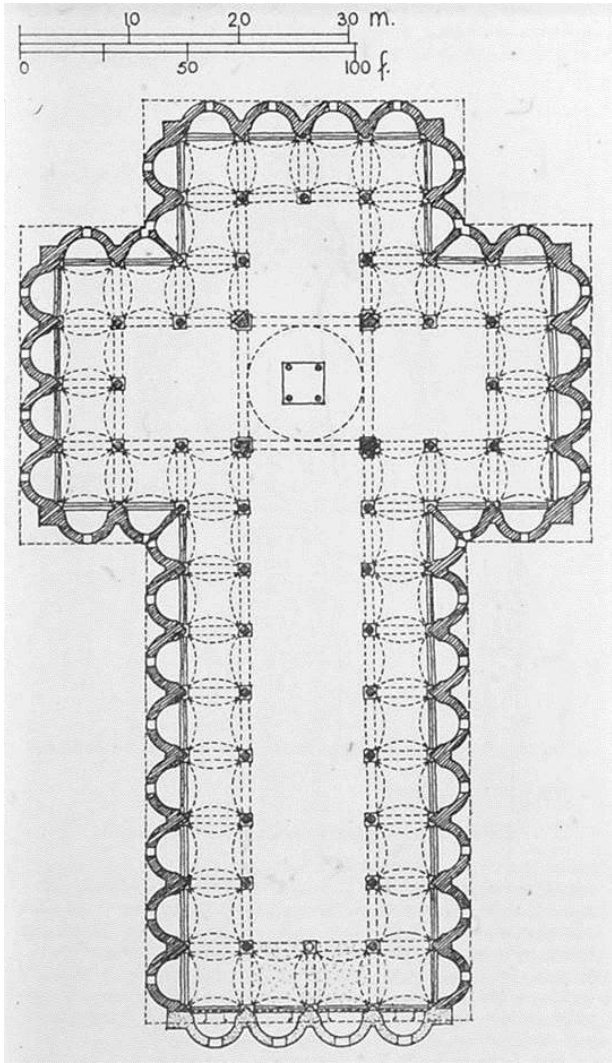

Firenze, chiesa di S. Spirito

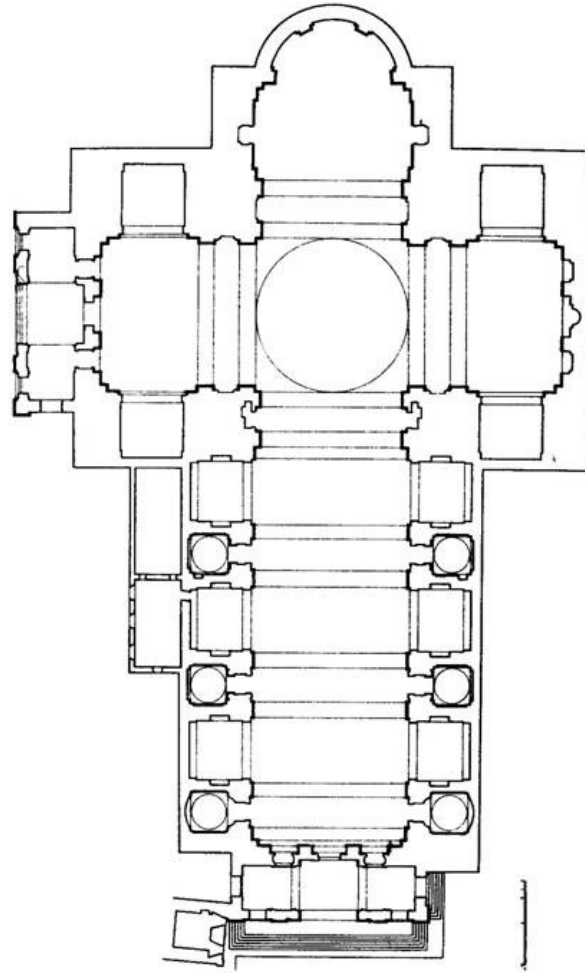

Mantova, chiesa di S. Andrea

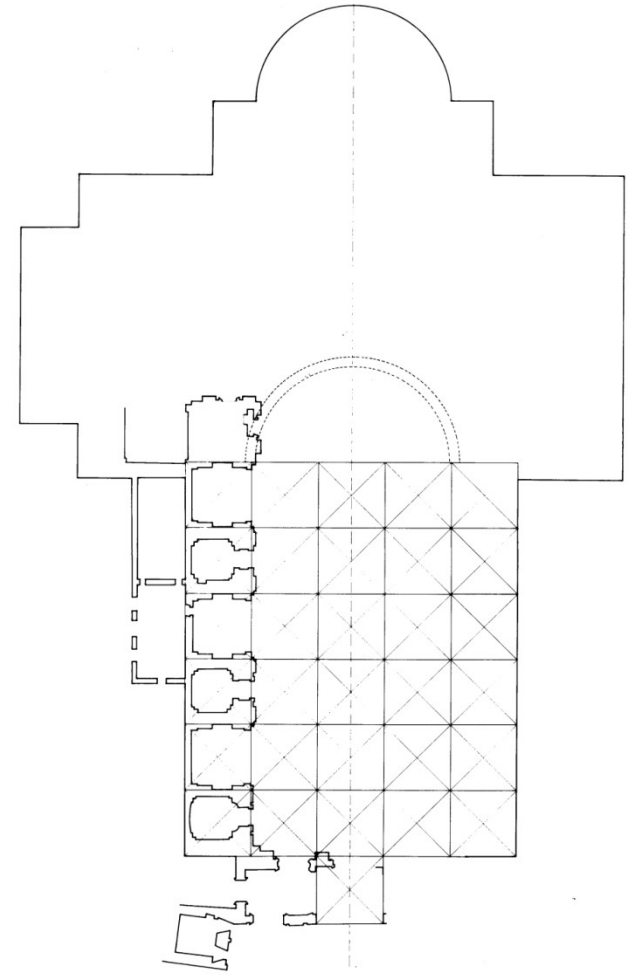

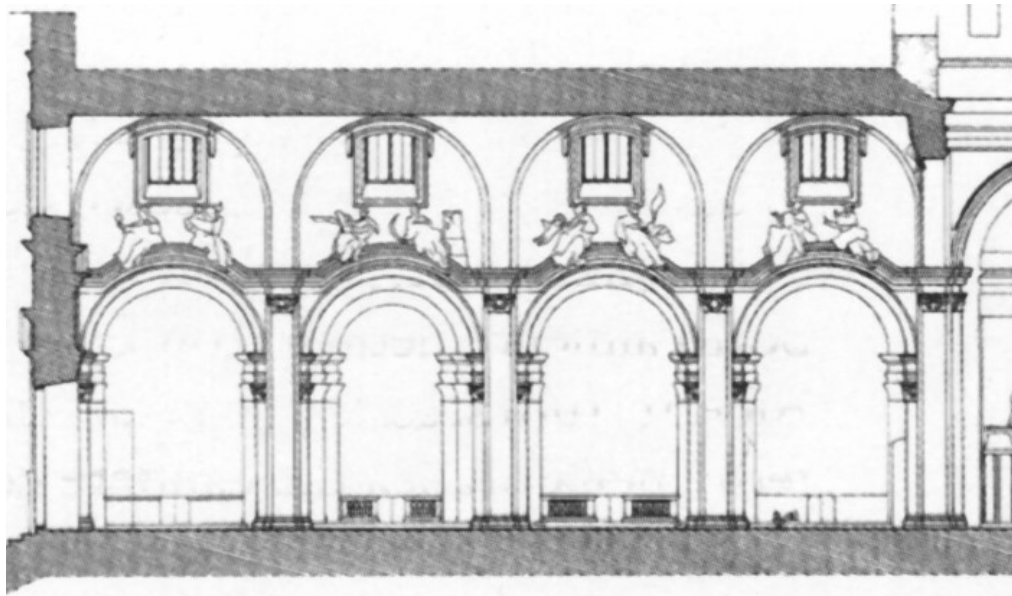

**Roma, Santa Maria del Popolo:
pianta e sezione longitudinale
di una campata secondo lo stato
quattrocentesco (ordine semplificato)**

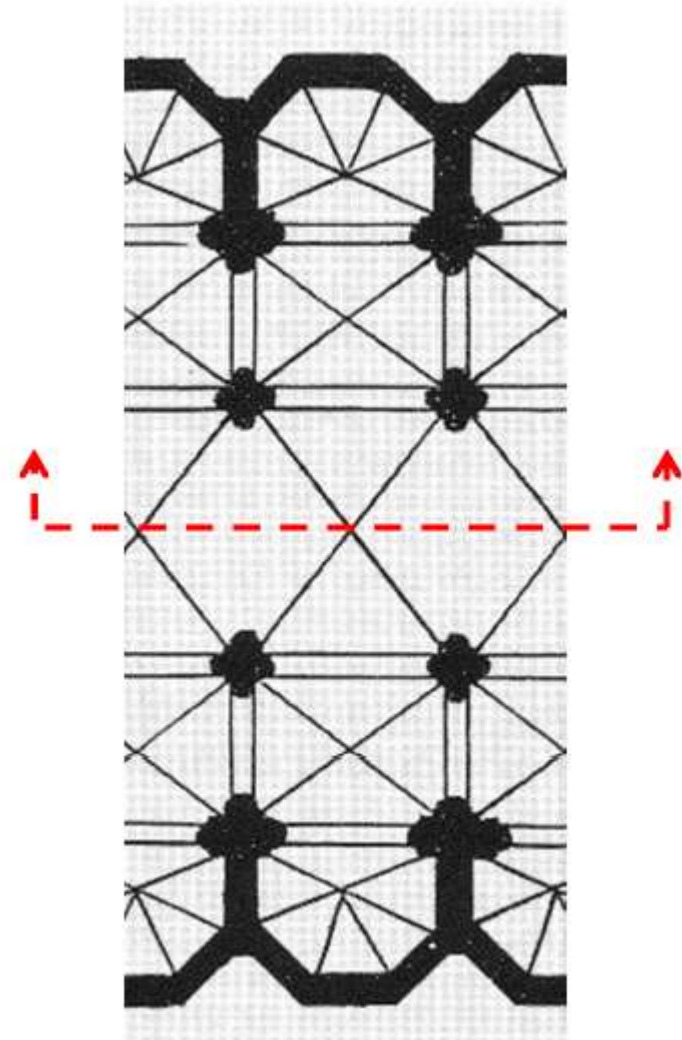
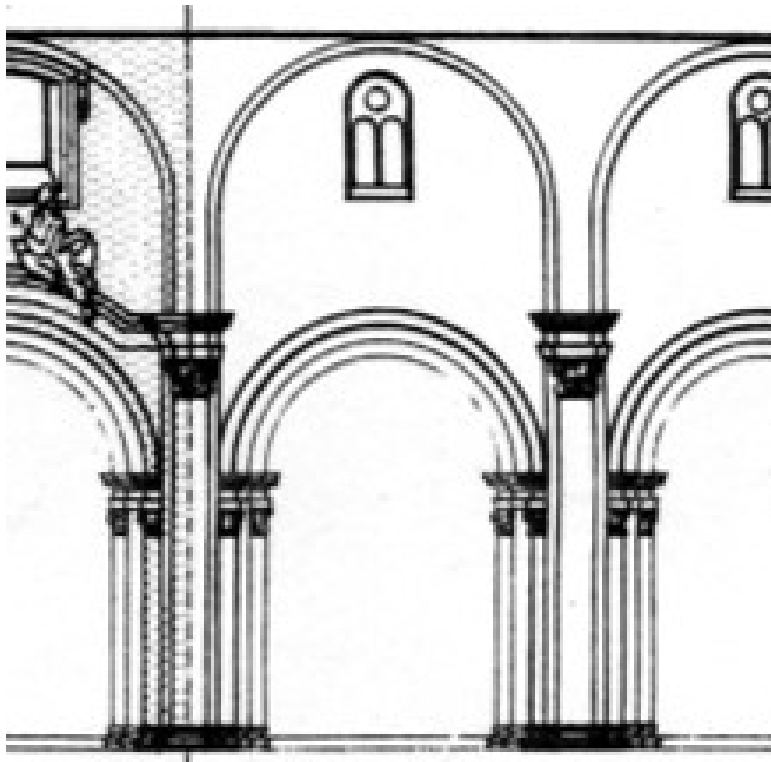

Ridisegno del sintagma brunelleschiano e applicazione dello stesso schema nelle due chiese ferraresi



Ferrara, Santa Maria in Vado

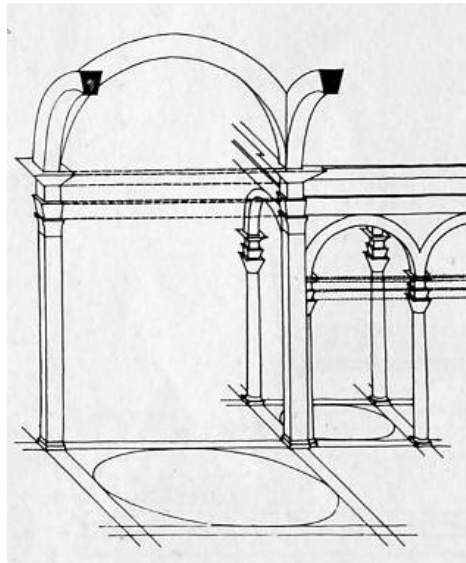

sintagma
brunelleschiano

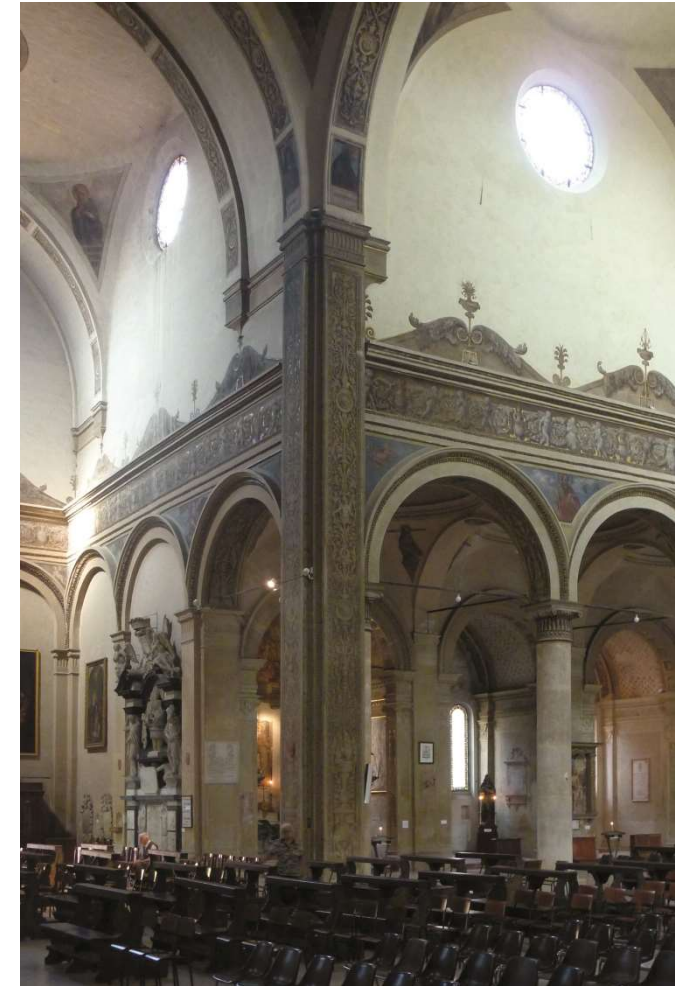

Ferrara, San Francesco

Diverse scelte progettuali in rapporto al contesto urbano, alla forma e alle caratteristiche dell'area

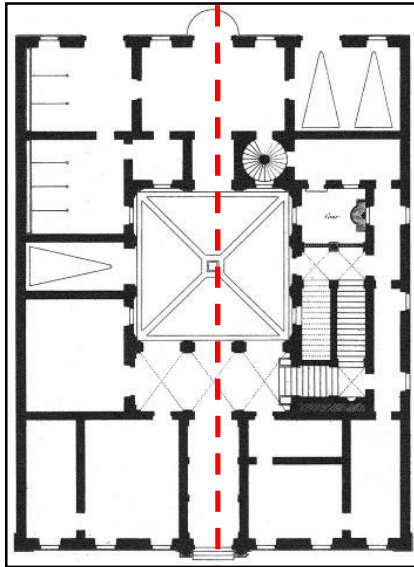

Palazzo Baldassini,
Antonio da Sangallo il
Giovane

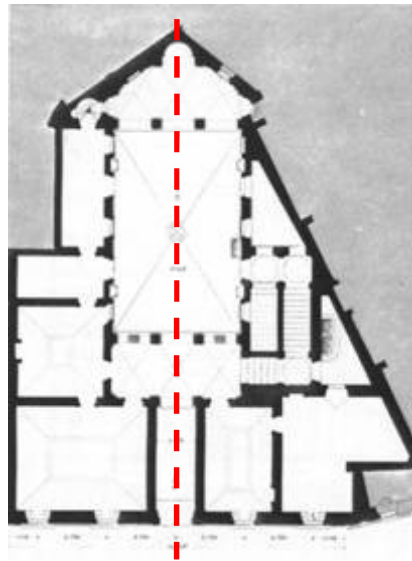

Palazzo di Angelo Massimo,
Giovanni Mangone



Casa di Raffaello
in via Giulia,
Raffaello Sanzio

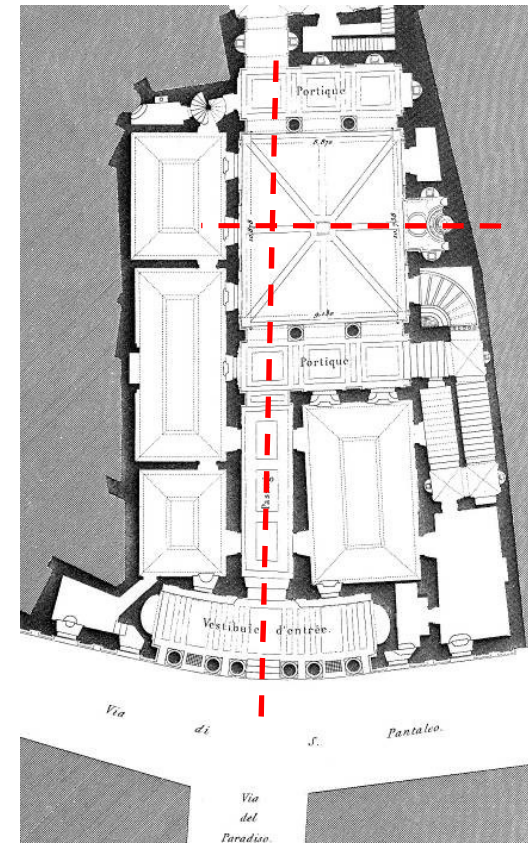

Palazzo Massimo alle
Colonne, Baldassare Peruzzi

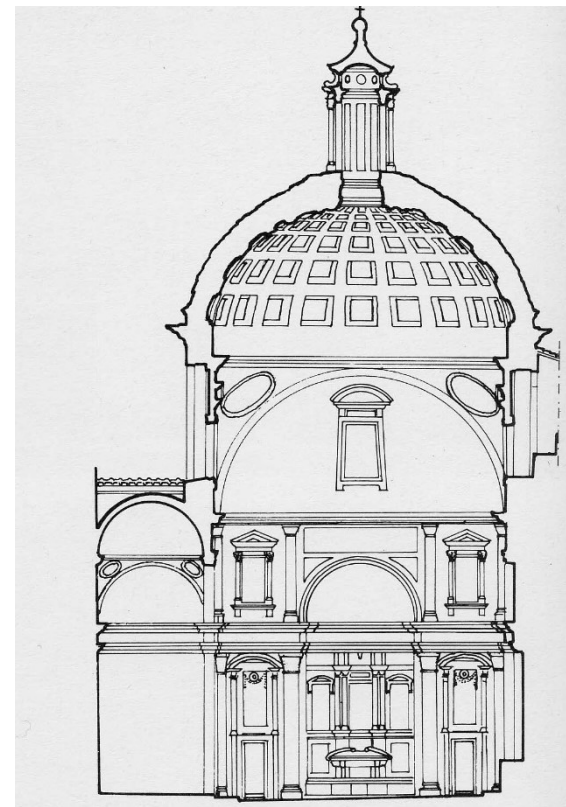
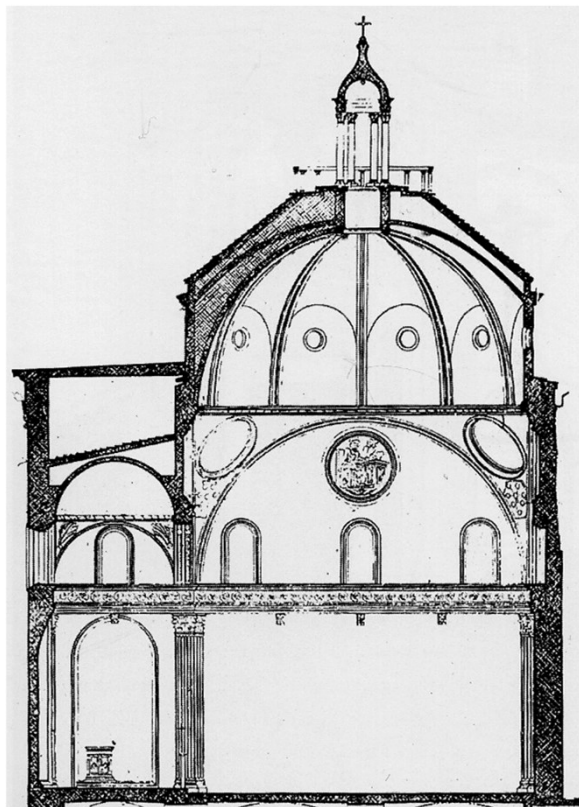
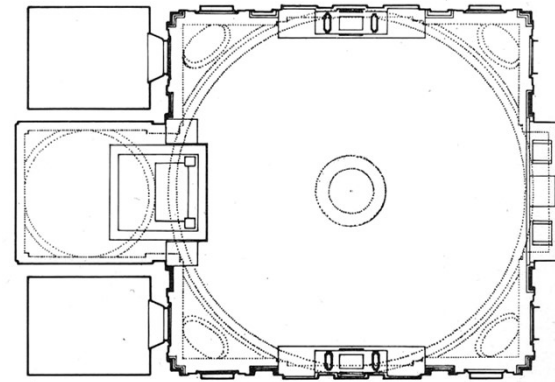
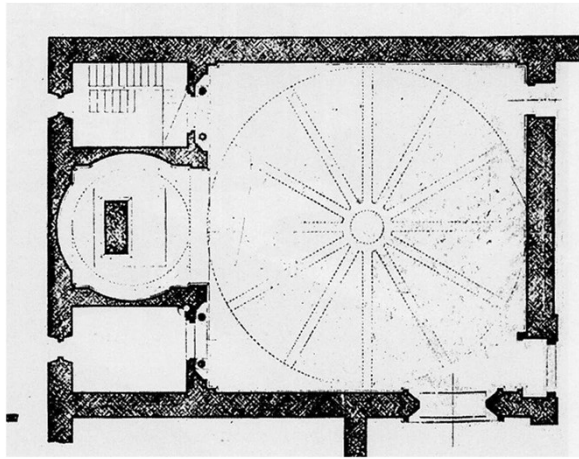

Firenze, S. Lorenzo, Sacrestia Vecchia e Sacrestia Nuova

**Venezia, chiesa del Redentore: pianta
e prospetto (ordine semplificato)**

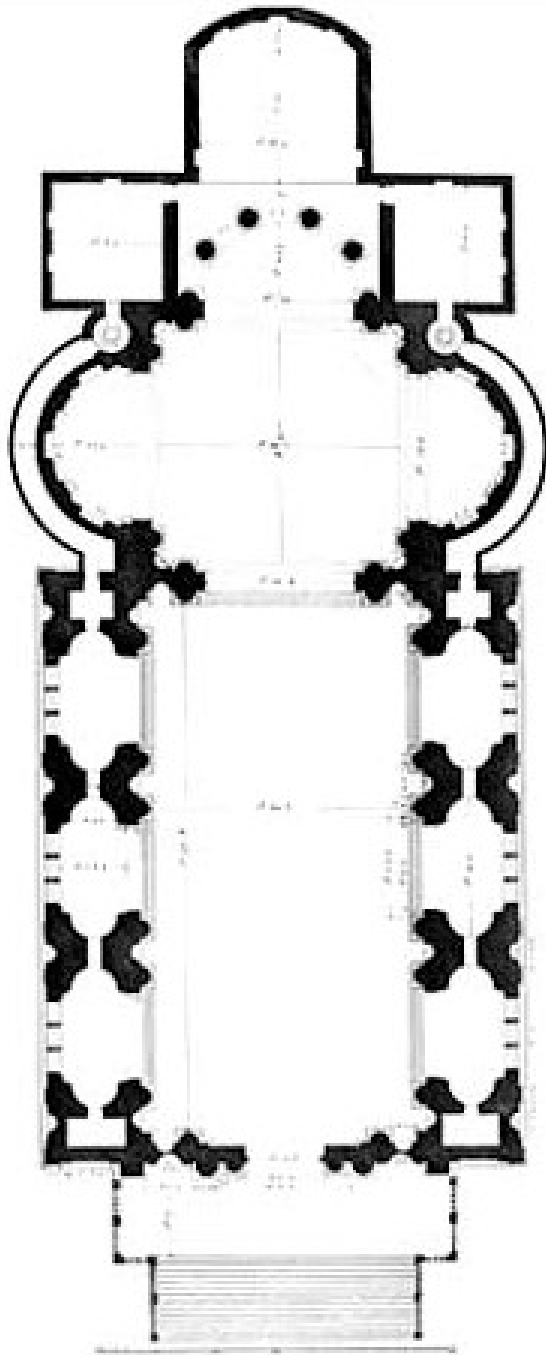

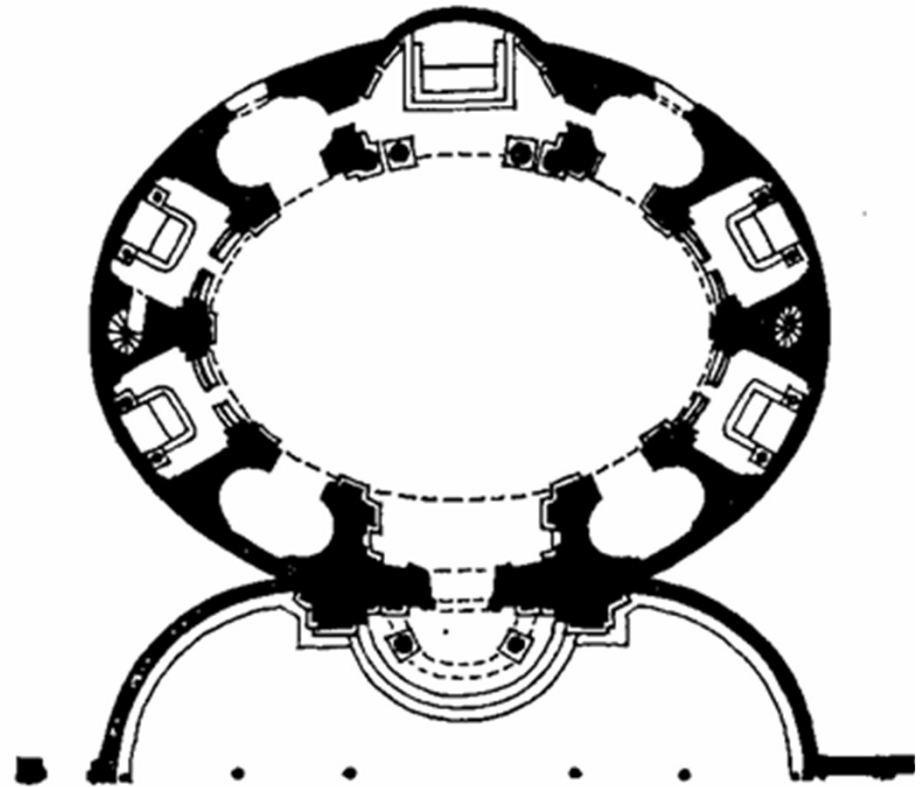
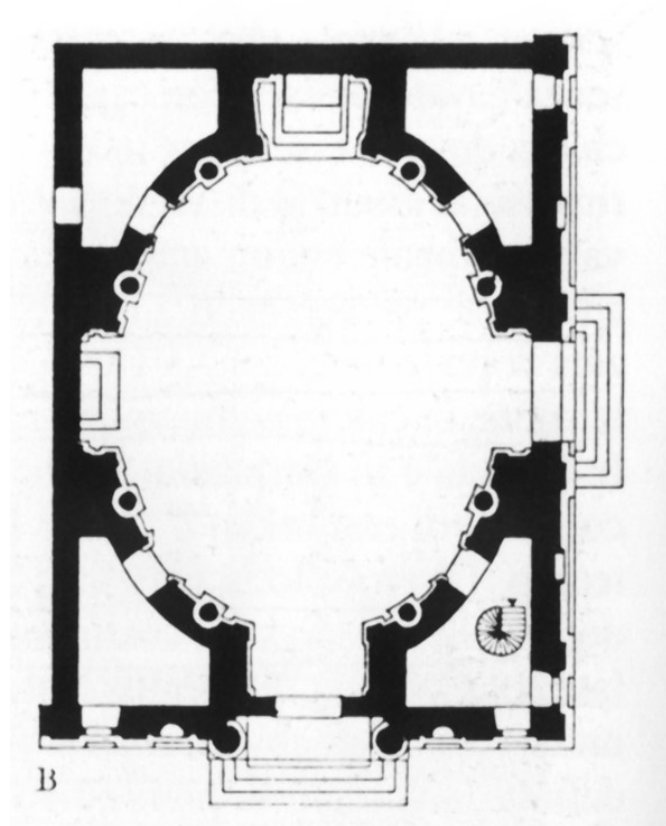

Roma, chiese di S. Anna dei Palafrenieri e di S. Andrea al Quirinale

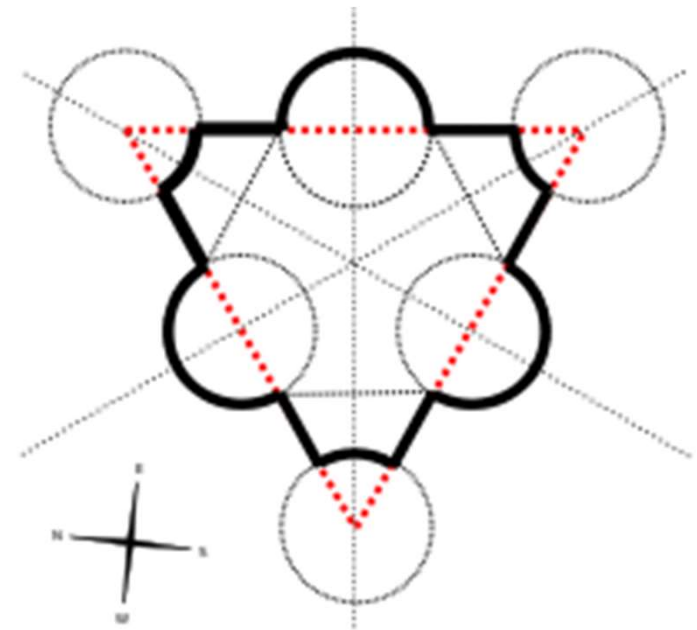
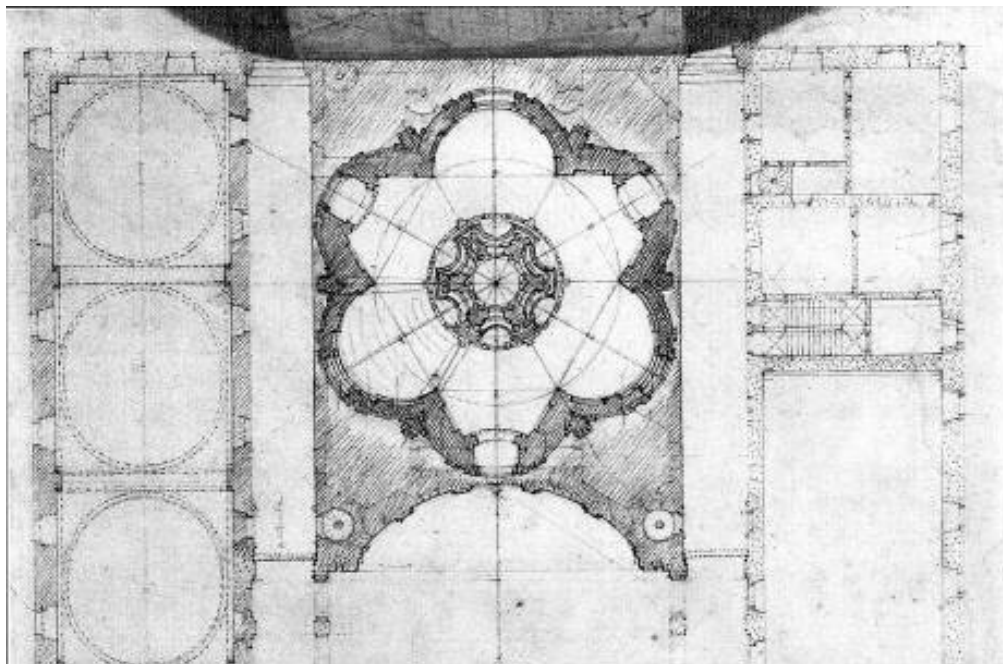
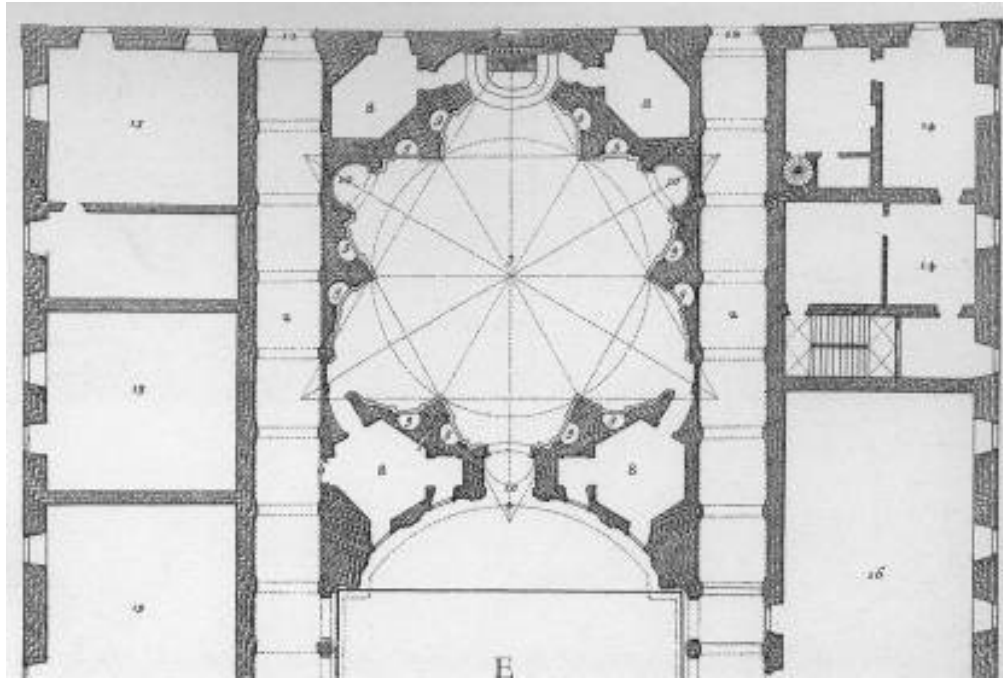

**Roma, chiesa di Sant'Ivo
alla Sapienza**

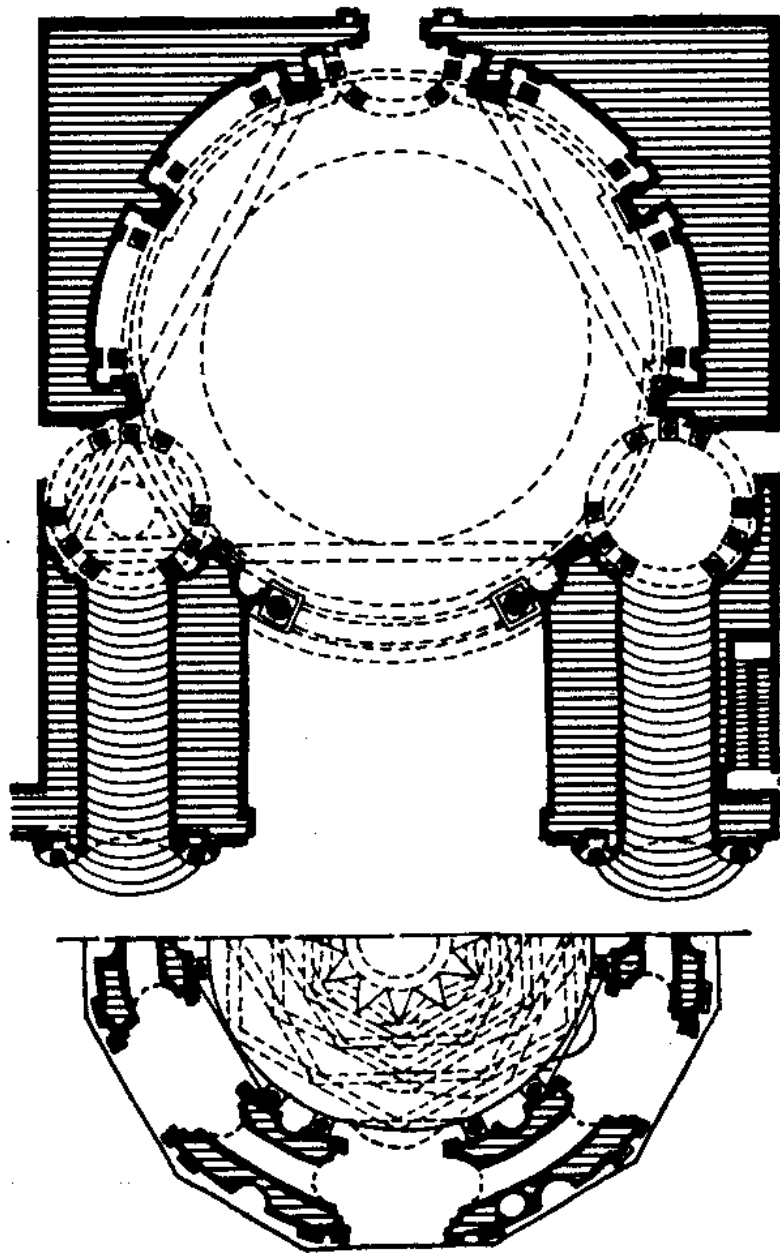

Torino, cappella della Sindone



**Santuario di Vallinotto
Presso Carignano**