

Galileo Galilei (1564–1642), an Italian astronomer, philosopher, and professor of mathematics at the Universities of Pisa and Padua, in 1609 became the first man to point a telescope to the sky. He wrote the first treatise on modern dynamics in 1590. His works on the oscillations of a simple pendulum and the vibration of strings are of fundamental significance in the theory of vibrations. (Courtesy of Dirk J. Struik, *A Concise History of Mathematics* (2nd rev. ed.), Dover Publications, Inc., New York, 1948.)

CHAPTER 1

Fundamentals of Vibration

Chapter Outline

Chapter Outline	1	1.9 Damping Elements	45
Learning Objectives	2	1.10 Harmonic Motion	54
1.1 Preliminary Remarks	2	1.11 Harmonic Analysis	64
1.2 Brief History of the Study of Vibration	3	1.12 Examples Using MATLAB	76
1.3 Importance of the Study of Vibration	10	1.13 Vibration Literature	80
1.4 Basic Concepts of Vibration	13	Chapter Summary	81
1.5 Classification of Vibration	16	References	81
1.6 Vibration Analysis Procedure	18	Review Questions	83
1.7 Spring Elements	22	Problems	87
1.8 Mass or Inertia Elements	40	Design Projects	120

This chapter introduces the subject of vibrations in a relatively simple manner. It begins with a brief history of the subject and continues with an examination of the importance of vibration. The basic concepts of degrees of freedom and of discrete and continuous systems are introduced, along with a description of the elementary parts of vibrating

systems. The various classifications of vibration—namely, free and forced vibration, undamped and damped vibration, linear and nonlinear vibration, and deterministic and random vibration—are indicated. The various steps involved in vibration analysis of an engineering system are outlined, and essential definitions and concepts of vibration are introduced.

The concept of harmonic motion and its representation using vectors and complex numbers is described. The basic definitions and terminology related to harmonic motion, such as cycle, amplitude, period, frequency, phase angle, and natural frequency, are given. Finally, the harmonic analysis, dealing with the representation of any periodic function in terms of harmonic functions, using Fourier series, is outlined. The concepts of frequency spectrum, time- and frequency-domain representations of periodic functions, half-range expansions, and numerical computation of Fourier coefficients are discussed in detail.

Learning Objectives

After completing this chapter, the reader should be able to do the following:

- Describe briefly the history of vibration
- Indicate the importance of study of vibration
- Give various classifications of vibration
- State the steps involved in vibration analysis
- Compute the values of spring constants, masses, and damping constants
- Define harmonic motion and different possible representations of harmonic motion
- Add and subtract harmonic motions
- Conduct Fourier series expansion of given periodic functions
- Determine Fourier coefficients numerically using the MATLAB program

1.1 Preliminary Remarks

The subject of vibration is introduced here in a relatively simple manner. The chapter begins with a brief history of vibration and continues with an examination of its importance. The various steps involved in vibration analysis of an engineering system are outlined, and essential definitions and concepts of vibration are introduced. We learn here that all mechanical and structural systems can be modeled as mass-spring-damper systems. In some systems, such as an automobile, the mass, spring and damper can be identified as separate components (mass in the form of the body, spring in the form of suspension and damper in the form of shock absorbers). In some cases, the mass, spring and damper do not appear as separate components; they are inherent and integral to the system. For example, in an airplane wing, the mass of the wing is distributed throughout the wing. Also, due to its elasticity, the wing undergoes noticeable deformation during flight so that it can be modeled as a spring. In addition, the deflection of the wing introduces damping due to relative motion between components such as joints, connections and support as well as internal friction due to microstructural defects in the material. The chapter describes the

modeling of spring, mass and damping elements, their characteristics and the combination of several springs, masses or damping elements appearing in a system. There follows a presentation of the concept of harmonic analysis, which can be used for the analysis of general periodic motions. No attempt at exhaustive treatment of the topics is made in Chapter 1; subsequent chapters will develop many of the ideas in more detail.

1.2 Brief History of the Study of Vibration

1.2.1 Origins of the Study of Vibration

People became interested in vibration when they created the first musical instruments, probably whistles or drums. Since then, both musicians and philosophers have sought out the rules and laws of sound production, used them in improving musical instruments, and passed them on from generation to generation. As long ago as 4000 B.C. [1.1], music had become highly developed and was much appreciated by Chinese, Hindus, Japanese, and, perhaps, the Egyptians. These early peoples observed certain definite rules in connection with the art of music, although their knowledge did not reach the level of a science.

Stringed musical instruments probably originated with the hunter's bow, a weapon favored by the armies of ancient Egypt. One of the most primitive stringed instruments, the *nanga*, resembled a harp with three or four strings, each yielding only one note. An example dating back to 1500 B.C. can be seen in the British Museum. The Museum also exhibits an 11-stringed harp with a gold-decorated, bull-headed sounding box, found at Ur in a royal tomb dating from about 2600 B.C. As early as 3000 B.C., stringed instruments such as harps were depicted on walls of Egyptian tombs.

Our present system of music is based on ancient Greek civilization. The Greek philosopher and mathematician Pythagoras (582–507 B.C.) is considered to be the first person to investigate musical sounds on a scientific basis (Fig. 1.1). Among other things, Pythagoras

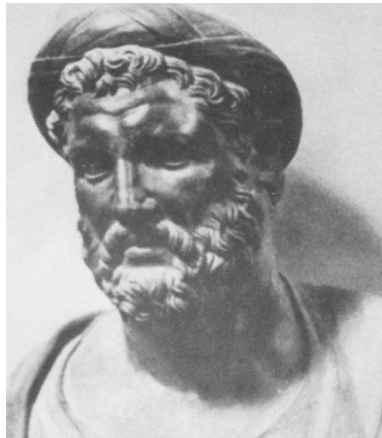

FIGURE 1.1 Pythagoras. (Reprinted with permission from L. E. Navia, *Pythagoras: An Annotated Bibliography*, Garland Publishing, Inc., New York, 1990).

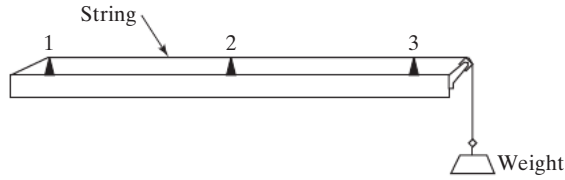

FIGURE 1.2 Monochord.

conducted experiments on a vibrating string by using a simple apparatus called a monochord. In the monochord shown in Fig. 1.2 the wooden bridges labeled 1 and 3 are fixed. Bridge 2 is made movable while the tension in the string is held constant by the hanging weight. Pythagoras observed that if two like strings of different lengths are subject to the same tension, the shorter one emits a higher note; in addition, if the shorter string is half the length of the longer one, the shorter one will emit a note an octave above the other. Pythagoras left no written account of his work (Fig. 1.3), but it has been described by others. Although the concept of pitch was developed by the time of Pythagoras, the relation between the pitch and the frequency was not understood until the time of Galileo in the sixteenth century.

Around 350 B.C., Aristotle wrote treatises on music and sound, making observations such as “the voice is sweeter than the sound of instruments,” and “the sound of the flute is sweeter than that of the lyre.” In 320 B.C., Aristoxenus, a pupil of Aristotle and a musician,

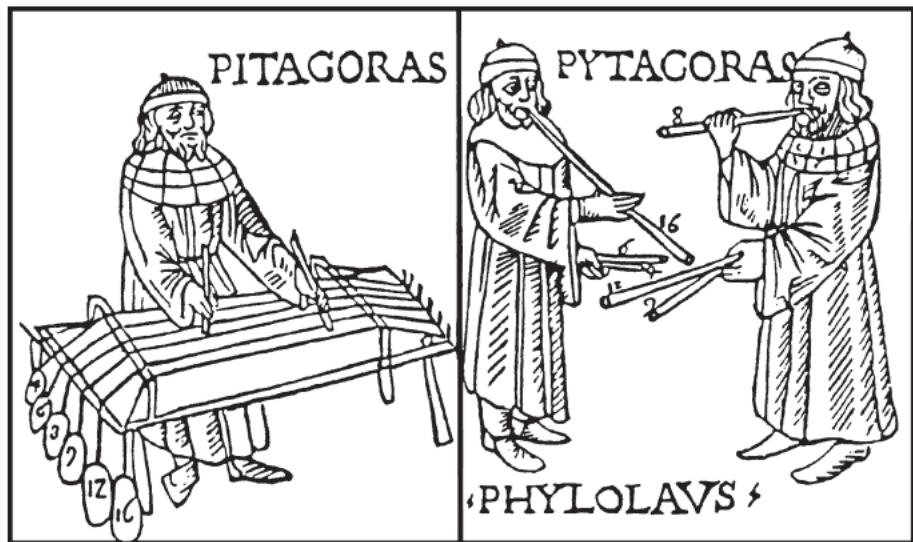

FIGURE 1.3 Pythagoras as a musician. (Reprinted with permission from D. E. Smith, *History of Mathematics*, Vol. I, Dover Publications, Inc., New York, 1958.)

wrote a three-volume work entitled *Elements of Harmony*. These books are perhaps the oldest ones available on the subject of music written by the investigators themselves. In about 300 B.C., in a treatise called *Introduction to Harmonics*, Euclid, wrote briefly about music without any reference to the physical nature of sound. No further advances in scientific knowledge of sound were made by the Greeks.

It appears that the Romans derived their knowledge of music completely from the Greeks, except that Vitruvius, a famous Roman architect, wrote in about 20 B.C. on the acoustic properties of theaters. His treatise, entitled *De Architectura Libri Decem*, was lost for many years, to be rediscovered only in the fifteenth century. There appears to have been no development in the theories of sound and vibration for nearly 16 centuries after the work of Vitruvius.

China experienced many earthquakes in ancient times. Zhang Heng, who served as a historian and astronomer in the second century, perceived a need to develop an instrument to measure earthquakes precisely. In A.D. 132 he invented the world's first seismograph [1.3, 1.4]. It was made of fine cast bronze, had a diameter of eight chi (a chi is equal to 0.237 meter), and was shaped like a wine jar (Fig. 1.4). Inside the jar was a mechanism consisting of pendulums surrounded by a group of eight levers pointing in eight directions. Eight dragon figures, with a bronze ball in the mouth of each, were arranged on the outside of the seismograph. Below each dragon was a toad with mouth open upward. A strong earthquake in any direction would tilt the pendulum in that direction, triggering the lever in the dragon head. This opened the mouth of the dragon, thereby releasing its bronze ball, which fell in the mouth of the toad with a clanging sound. Thus the seismograph enabled the monitoring personnel to know both the time and direction of occurrence of the earthquake.



世界首創之地震儀外觀之想像圖

FIGURE 1.4 The world's first seismograph, invented in China in A.D. 132. (Reprinted with permission from R. Taton (ed.), *History of Science*, Basic Books, Inc., New York, 1957.)

1.2.2 From Galileo to Rayleigh

Galileo Galilei (1564–1642) is considered to be the founder of modern experimental science. In fact, the seventeenth century is often considered the “century of genius” since the foundations of modern philosophy and science were laid during that period. Galileo was inspired to study the behavior of a simple pendulum by observing the pendulum movements of a lamp in a church in Pisa. One day, while feeling bored during a sermon, Galileo was staring at the ceiling of the church. A swinging lamp caught his attention. He started measuring the period of the pendulum movements of the lamp with his pulse and found to his amazement that the time period was independent of the amplitude of swings. This led him to conduct more experiments on the simple pendulum. In *Discourses Concerning Two New Sciences*, published in 1638, Galileo discussed vibrating bodies. He described the dependence of the frequency of vibration on the length of a simple pendulum, along with the phenomenon of sympathetic vibrations (resonance). Galileo’s writings also indicate that he had a clear understanding of the relationship between the frequency, length, tension, and density of a vibrating stretched string [1.5]. However, the first correct published account of the vibration of strings was given by the French mathematician and theologian, Marin Mersenne (1588–1648) in his book *Harmonicorum Liber*, published in 1636. Mersenne also measured, for the first time, the frequency of vibration of a long string and from that predicted the frequency of a shorter string having the same density and tension. Mersenne is considered by many the father of acoustics. He is often credited with the discovery of the laws of vibrating strings because he published the results in 1636, two years before Galileo. However, the credit belongs to Galileo, since the laws were written many years earlier but their publication was prohibited by the orders of the Inquisitor of Rome until 1638.

Inspired by the work of Galileo, the Academia del Cimento was founded in Florence in 1657; this was followed by the formations of the Royal Society of London in 1662 and the Paris Academie des Sciences in 1666. Later, Robert Hooke (1635–1703) also conducted experiments to find a relation between the pitch and frequency of vibration of a string. However, it was Joseph Sauveur (1653–1716) who investigated these experiments thoroughly and coined the word “acoustics” for the science of sound [1.6]. Sauveur in France and John Wallis (1616–1703) in England observed, independently, the phenomenon of mode shapes, and they found that a vibrating stretched string can have no motion at certain points and violent motion at intermediate points. Sauveur called the former points *nodes* and the latter ones *loops*. It was found that such vibrations had higher frequencies than that associated with the simple vibration of the string with no nodes. In fact, the higher frequencies were found to be integral multiples of the frequency of simple vibration, and Sauveur called the higher frequencies harmonics and the frequency of simple vibration the fundamental frequency. Sauveur also found that a string can vibrate with several of its harmonics present at the same time. In addition, he observed the phenomenon of beats when two organ pipes of slightly different pitches are sounded together. In 1700 Sauveur calculated, by a somewhat dubious method, the frequency of a stretched string from the measured sag of its middle point.

Sir Isaac Newton (1642–1727) published his monumental work, *Philosophiae Naturalis Principia Mathematica*, in 1686, describing the law of universal gravitation as well as the three laws of motion and other discoveries. Newton’s second law of motion is routinely used in modern books on vibrations to derive the equations of motion of a

vibrating body. The theoretical (dynamical) solution of the problem of the vibrating string was found in 1713 by the English mathematician Brook Taylor (1685–1731), who also presented the famous Taylor's theorem on infinite series. The natural frequency of vibration obtained from the equation of motion derived by Taylor agreed with the experimental values observed by Galileo and Mersenne. The procedure adopted by Taylor was perfected through the introduction of partial derivatives in the equations of motion by Daniel Bernoulli (1700–1782), Jean D'Alembert (1717–1783), and Leonard Euler (1707–1783).

The possibility of a string vibrating with several of its harmonics present at the same time (with displacement of any point at any instant being equal to the algebraic sum of displacements for each harmonic) was proved through the dynamic equations of Daniel Bernoulli in his memoir, published by the Berlin Academy in 1755 [1.7]. This characteristic was referred to as the principle of the coexistence of small oscillations, which, in present-day terminology, is the principle of superposition. This principle was proved to be most valuable in the development of the theory of vibrations and led to the possibility of expressing any arbitrary function (i.e., any initial shape of the string) using an infinite series of sines and cosines. Because of this implication, D'Alembert and Euler doubted the validity of this principle. However, the validity of this type of expansion was proved by J. B. J. Fourier (1768–1830) in his *Analytical Theory of Heat* in 1822.

The analytical solution of the vibrating string was presented by Joseph Lagrange (1736–1813) in his memoir published by the Turin Academy in 1759. In his study, Lagrange assumed that the string was made up of a finite number of equally spaced identical mass particles, and he established the existence of a number of independent frequencies equal to the number of mass particles. When the number of particles was allowed to be infinite, the resulting frequencies were found to be the same as the harmonic frequencies of the stretched string. The method of setting up the differential equation of the motion of a string (called the wave equation), presented in most modern books on vibration theory, was first developed by D'Alembert in his memoir published by the Berlin Academy in 1750. The vibration of thin beams supported and clamped in different ways was first studied by Euler in 1744 and Daniel Bernoulli in 1751. Their approach has become known as the Euler-Bernoulli or thin beam theory.

Charles Coulomb did both theoretical and experimental studies in 1784 on the torsional oscillations of a metal cylinder suspended by a wire (Fig. 1.5). By assuming that the resisting torque of the twisted wire is proportional to the angle of twist, he derived the equation of motion for the torsional vibration of the suspended cylinder. By integrating the equation of motion, he found that the period of oscillation is independent of the angle of twist.

There is an interesting story related to the development of the theory of vibration of plates [1.8]. In 1802 the German scientist, E. F. F. Chladni (1756–1824) developed the method of placing sand on a vibrating plate to find its mode shapes and observed the beauty and intricacy of the modal patterns of the vibrating plates. In 1809 the French Academy invited Chladni to give a demonstration of his experiments. Napoléon Bonaparte, who attended the meeting, was very impressed and presented a sum of 3,000 francs to the academy, to be awarded to the first person to give a satisfactory mathematical theory of the vibration of plates. By the closing date of the competition in October

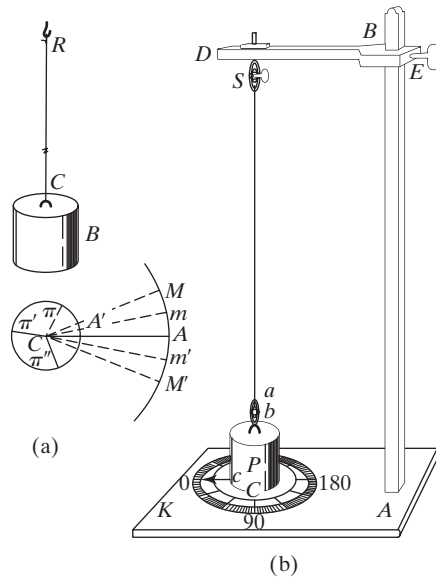

FIGURE 1.5 Coulomb's device for torsional vibration tests. (Reprinted with permission from S. P. Timoshenko, *History of Strength of Materials*, McGraw-Hill Book Company, Inc., New York, 1953.)

1811, only one candidate, Sophie Germain, had entered the contest. But Lagrange, who was one of the judges, noticed an error in the derivation of her differential equation of motion. The academy opened the competition again, with a new closing date of October 1813. Sophie Germain again entered the contest, presenting the correct form of the differential equation. However, the academy did not award the prize to her because the judges wanted physical justification of the assumptions made in her derivation. The competition was opened once more. In her third attempt, Sophie Germain was finally awarded the prize in 1815, although the judges were not completely satisfied with her theory. In fact, it was later found that her differential equation was correct but the boundary conditions were erroneous. The correct boundary conditions for the vibration of plates were given in 1850 by G. R. Kirchhoff (1824–1887).

In the meantime, the problem of vibration of a rectangular flexible membrane, which is important for the understanding of the sound emitted by drums, was solved for the first time by Simeon Poisson (1781–1840). The vibration of a circular membrane was studied by R. F. A. Clebsch (1833–1872) in 1862. After this, vibration studies were done on a number of practical mechanical and structural systems. In 1877 Lord Baron Rayleigh published his book on the theory of sound [1.9]; it is considered a classic on the subject of sound and vibration even today. Notable among the many contributions of Rayleigh is the method of finding the fundamental frequency of vibration of a conservative system by making use of the principle of conservation of energy—now known as Rayleigh's method.

This method proved to be a helpful technique for the solution of difficult vibration problems. An extension of the method, which can be used to find multiple natural frequencies, is known as the Rayleigh-Ritz method.

1.2.3 Recent Contributions

In 1902 Frahm investigated the importance of torsional vibration study in the design of the propeller shafts of steamships. The dynamic vibration absorber, which involves the addition of a secondary spring-mass system to eliminate the vibrations of a main system, was also proposed by Frahm in 1909. Among the modern contributors to the theory of vibrations, the names of Stodola, De Laval, Timoshenko, and Mindlin are notable. Aurel Stodola (1859–1943) contributed to the study of vibration of beams, plates, and membranes. He developed a method for analyzing vibrating beams that is also applicable to turbine blades. Noting that every major type of prime mover gives rise to vibration problems, C. G. P. De Laval (1845–1913) presented a practical solution to the problem of vibration of an unbalanced rotating disk. After noticing failures of steel shafts in high-speed turbines, he used a bamboo fishing rod as a shaft to mount the rotor. He observed that this system not only eliminated the vibration of the unbalanced rotor but also survived up to speeds as high as 100,000 rpm [1.10].

Stephen Timoshenko (1878–1972), by considering the effects of rotary inertia and shear deformation, presented an improved theory of vibration of beams, which has become known as the Timoshenko or thick beam theory. A similar theory was presented by R. D. Mindlin for the vibration analysis of thick plates by including the effects of rotary inertia and shear deformation.

It has long been recognized that many basic problems of mechanics, including those of vibrations, are nonlinear. Although the linear treatments commonly adopted are quite satisfactory for most purposes, they are not adequate in all cases. In nonlinear systems, phenomena may occur that are theoretically impossible in linear systems. The mathematical theory of nonlinear vibrations began to develop in the works of Poincaré and Lyapunov at the end of the nineteenth century. Poincaré developed the perturbation method in 1892 in connection with the approximate solution of nonlinear celestial mechanics problems. In 1892, Lyapunov laid the foundations of modern stability theory, which is applicable to all types of dynamical systems. After 1920, the studies undertaken by Duffing and van der Pol brought the first definite solutions into the theory of nonlinear vibrations and drew attention to its importance in engineering. In the last 40 years, authors like Minorsky and Stoker have endeavored to collect in monographs the main results concerning nonlinear vibrations. Most practical applications of nonlinear vibration involved the use of some type of a perturbation-theory approach. The modern methods of perturbation theory were surveyed by Nayfeh [1.11].

Random characteristics are present in diverse phenomena such as earthquakes, winds, transportation of goods on wheeled vehicles, and rocket and jet engine noise. It became necessary to devise concepts and methods of vibration analysis for these random effects. Although Einstein considered Brownian movement, a particular type of random vibration, as long ago as 1905, no applications were investigated until 1930. The introduction of the correlation function by Taylor in 1920 and of the spectral density by Wiener and Khinchin in the early 1930s opened new prospects for progress in the theory of random vibrations. Papers by Lin and Rice, published between 1943 and 1945, paved

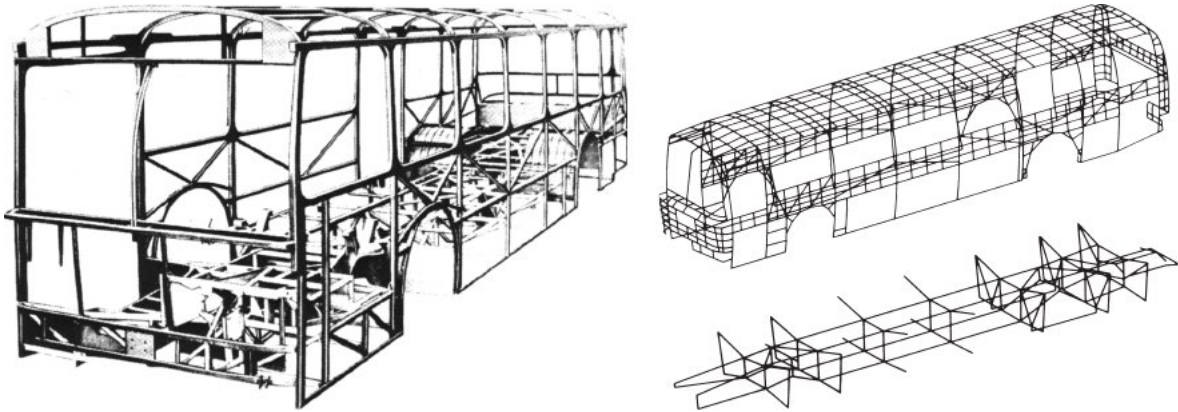

FIGURE 1.6 Finite element idealization of the body of a bus [1.16]. (Reprinted with permission © 1974 Society of Automotive Engineers, Inc.)

the way for the application of random vibrations to practical engineering problems. The monographs of Crandall and Mark and of Robson systematized the existing knowledge in the theory of random vibrations [1.12, 1.13].

Until about 40 years ago, vibration studies, even those dealing with complex engineering systems, were done by using gross models, with only a few degrees of freedom. However, the advent of high-speed digital computers in the 1950s made it possible to treat moderately complex systems and to generate approximate solutions in semidefinite form, relying on classical solution methods but using numerical evaluation of certain terms that cannot be expressed in closed form. The simultaneous development of the finite element method enabled engineers to use digital computers to conduct numerically detailed vibration analysis of complex mechanical, vehicular, and structural systems displaying thousands of degrees of freedom [1.14]. Although the finite element method was not so named until recently, the concept was used centuries ago. For example, ancient mathematicians found the circumference of a circle by approximating it as a polygon, where each side of the polygon, in present-day notation, can be called a finite element. The finite element method as known today was presented by Turner, Clough, Martin, and Topp in connection with the analysis of aircraft structures [1.15]. Figure 1.6 shows the finite element idealization of the body of a bus [1.16].

1.3 Importance of the Study of Vibration

Most human activities involve vibration in one form or other. For example, we hear because our eardrums vibrate and see because light waves undergo vibration. Breathing is associated with the vibration of lungs and walking involves (periodic) oscillatory motion of legs and hands. Human speech requires the oscillatory motion of larynges (and tongues) [1.17]. Early scholars in the field of vibration concentrated their efforts on understanding the natural phenomena and developing mathematical theories to describe the vibration of physical systems. In recent times, many investigations have been motivated by the

engineering applications of vibration, such as the design of machines, foundations, structures, engines, turbines, and control systems.

Most prime movers have vibrational problems due to the inherent unbalance in the engines. The unbalance may be due to faulty design or poor manufacture. Imbalance in diesel engines, for example, can cause ground waves sufficiently powerful to create a nuisance in urban areas. The wheels of some locomotives can rise more than a centimeter off the track at high speeds due to imbalance. In turbines, vibrations cause spectacular mechanical failures. Engineers have not yet been able to prevent the failures that result from blade and disk vibrations in turbines. Naturally, the structures designed to support heavy centrifugal machines, like motors and turbines, or reciprocating machines, like steam and gas engines and reciprocating pumps, are also subjected to vibration. In all these situations, the structure or machine component subjected to vibration can fail because of material fatigue resulting from the cyclic variation of the induced stress. Furthermore, the vibration causes more rapid wear of machine parts such as bearings and gears and also creates excessive noise. In machines, vibration can loosen fasteners such as nuts. In metal cutting processes, vibration can cause chatter, which leads to a poor surface finish.

Whenever the natural frequency of vibration of a machine or structure coincides with the frequency of the external excitation, there occurs a phenomenon known as *resonance*, which leads to excessive deflections and failure. The literature is full of accounts of system failures brought about by resonance and excessive vibration of components and systems (see Fig. 1.7). Because of the devastating effects that vibrations can have on machines



FIGURE 1.7 Tacoma Narrows bridge during wind-induced vibration. The bridge opened on July 1, 1940, and collapsed on November 7, 1940. (Farquharson photo, Historical Photography Collection, University of Washington Libraries.)



FIGURE 1.8 Vibration testing of the space shuttle *Enterprise*. (Courtesy of NASA.)

and structures, vibration testing [1.18] has become a standard procedure in the design and development of most engineering systems (see Fig. 1.8).

In many engineering systems, a human being acts as an integral part of the system. The transmission of vibration to human beings results in discomfort and loss of efficiency. The vibration and noise generated by engines causes annoyance to people and, sometimes, damage to property. Vibration of instrument panels can cause their malfunction or difficulty in reading the meters [1.19]. Thus one of the important purposes of vibration study is to reduce vibration through proper design of machines and their mountings. In this

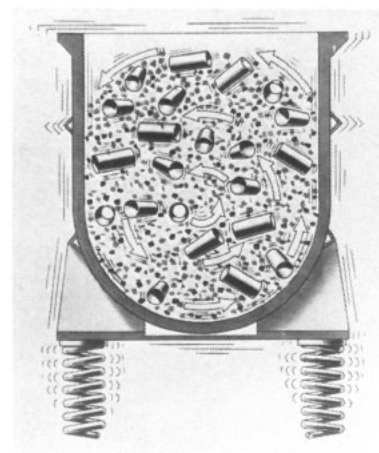
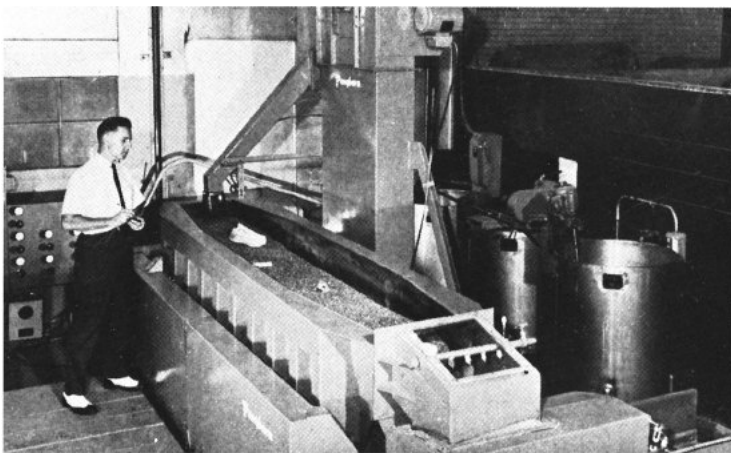

FIGURE 1.9 Vibratory finishing process. (Reprinted courtesy of the Society of Manufacturing Engineers, © 1964 The Tool and Manufacturing Engineer.)

connection, the mechanical engineer tries to design the engine or machine so as to minimize imbalance, while the structural engineer tries to design the supporting structure so as to ensure that the effect of the imbalance will not be harmful [1.20].

In spite of its detrimental effects, vibration can be utilized profitably in several consumer and industrial applications. In fact, the applications of vibratory equipment have increased considerably in recent years [1.21]. For example, vibration is put to work in vibratory conveyors, hoppers, sieves, compactors, washing machines, electric toothbrushes, dentist's drills, clocks, and electric massaging units. Vibration is also used in pile driving, vibratory testing of materials, vibratory finishing processes, and electronic circuits to filter out the unwanted frequencies (see Fig. 1.9). Vibration has been found to improve the efficiency of certain machining, casting, forging, and welding processes. It is employed to simulate earthquakes for geological research and also to conduct studies in the design of nuclear reactors.

1.4 Basic Concepts of Vibration

1.4.1 Vibration

Any motion that repeats itself after an interval of time is called *vibration* or *oscillation*. The swinging of a pendulum and the motion of a plucked string are typical examples of vibration. The theory of vibration deals with the study of oscillatory motions of bodies and the forces associated with them.

1.4.2 Elementary Parts of Vibrating Systems

A vibratory system, in general, includes a means for storing potential energy (spring or elasticity), a means for storing kinetic energy (mass or inertia), and a means by which energy is gradually lost (damper).

The vibration of a system involves the transfer of its potential energy to kinetic energy and of kinetic energy to potential energy, alternately. If the system is damped, some energy is dissipated in each cycle of vibration and must be replaced by an external source if a state of steady vibration is to be maintained.

As an example, consider the vibration of the simple pendulum shown in Fig. 1.10. Let the bob of mass m be released after being given an angular displacement θ . At position 1 the velocity of the bob and hence its kinetic energy is zero. But it has a potential energy of magnitude $mgl(1 - \cos \theta)$ with respect to the datum position 2. Since the gravitational force mg induces a torque $mgl \sin \theta$ about the point O , the bob starts swinging to the left from position 1. This gives the bob certain angular acceleration in the clockwise direction, and by the time it reaches position 2, all of its potential energy will be converted into kinetic energy. Hence the bob will not stop in position 2 but will continue to swing to position 3. However, as it passes the mean position 2, a counterclockwise torque due to gravity starts acting on the bob and causes the bob to decelerate. The velocity of the bob reduces to zero at the left extreme position. By this time, all the kinetic energy of the bob will be converted to potential energy. Again due to the gravity torque, the bob continues to attain a counterclockwise velocity. Hence the bob starts swinging back with progressively increasing velocity and passes the mean position again. This process keeps repeating, and the pendulum will have oscillatory motion. However, in practice, the magnitude of oscillation (θ) gradually decreases and the pendulum ultimately stops due to the resistance (damping) offered by the surrounding medium (air). This means that some energy is dissipated in each cycle of vibration due to damping by the air.

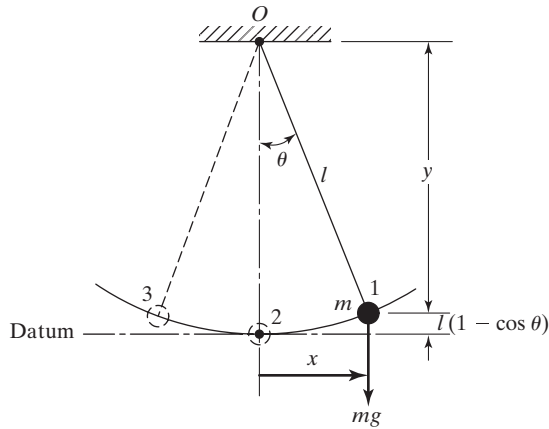

FIGURE 1.10 A simple pendulum.

1.4.3 Number of Degrees of Freedom

The minimum number of independent coordinates required to determine completely the positions of all parts of a system at any instant of time defines the number of degrees of freedom of the system. The simple pendulum shown in Fig. 1.10, as well as each of the systems shown in Fig. 1.11, represents a single-degree-of-freedom system. For example, the motion of the simple pendulum (Fig. 1.10) can be stated either in terms of the angle θ or in terms of the Cartesian coordinates x and y . If the coordinates x and y are used to describe the motion, it must be recognized that these coordinates are not independent. They are related to each other through the relation $x^2 + y^2 = l^2$, where l is the constant length of the pendulum. Thus any one coordinate can describe the motion of the pendulum. In this example, we find that the choice of θ as the independent coordinate will be more convenient than the choice of x or y . For the slider shown in Fig. 1.11 (a), either the angular coordinate θ or the coordinate x can be used to describe the motion. In Fig. 1.11 (b), the linear coordinate x can

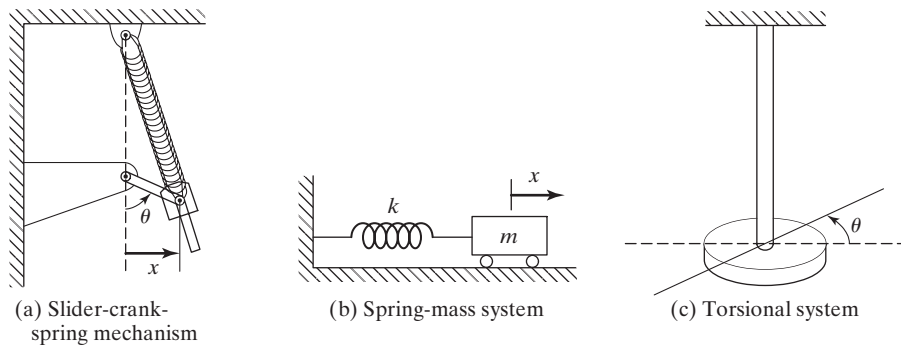

FIGURE 1.11 Single-degree-of-freedom systems.

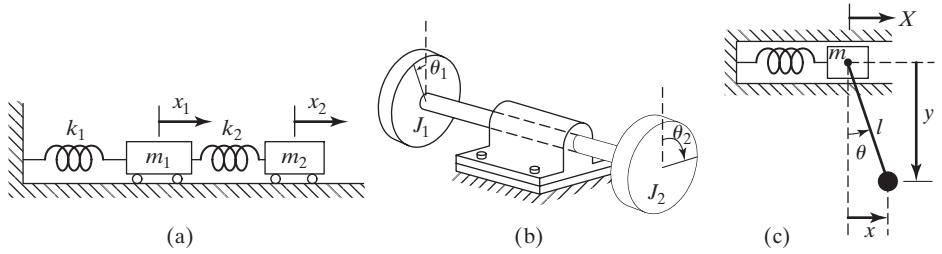

FIGURE 1.12 Two-degree-of-freedom systems.

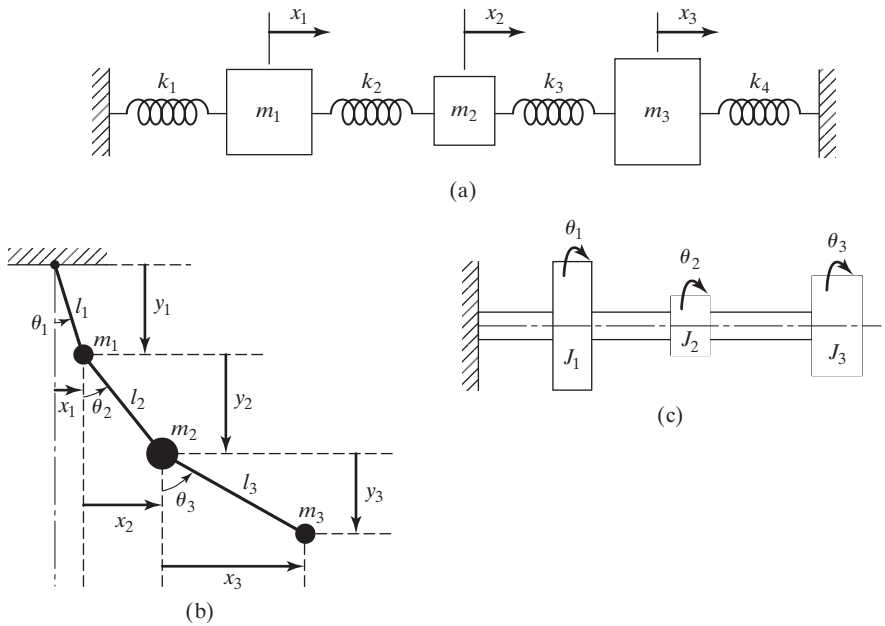

FIGURE 1.13 Three-degree-of-freedom systems.

be used to specify the motion. For the torsional system (long bar with a heavy disk at the end) shown in Fig. 1.11(c), the angular coordinate θ can be used to describe the motion.

Some examples of two- and three-degree-of-freedom systems are shown in Figs. 1.12 and 1.13, respectively. Figure 1.12(a) shows a two-mass, two-spring system that is described by the two linear coordinates x_1 and x_2 . Figure 1.12(b) denotes a two-rotor system whose motion can be specified in terms of θ_1 and θ_2 . The motion of the system shown in Fig. 1.12(c) can be described completely either by X and θ or by x , y , and X . In the latter case, x and y are constrained as $x^2 + y^2 = l^2$ where l is a constant.

For the systems shown in Figs. 1.13(a) and 1.13(c), the coordinates x_i ($i = 1, 2, 3$) and θ_i ($i = 1, 2, 3$) can be used, respectively, to describe the motion. In the case of the

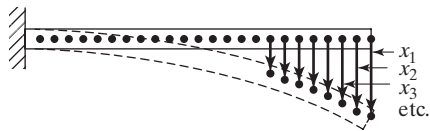

FIGURE 1.14 A cantilever beam (an infinite-number-of-degrees-of-freedom system).

system shown in Fig. 1.13(b), θ_i ($i = 1, 2, 3$) specifies the positions of the masses m_i ($i = 1, 2, 3$). An alternate method of describing this system is in terms of x_i and y_i ($i = 1, 2, 3$); but in this case the constraints $x_i^2 + y_i^2 = l_i^2$ ($i = 1, 2, 3$) have to be considered.

The coordinates necessary to describe the motion of a system constitute a set of *generalized coordinates*. These are usually denoted as q_1, q_2, \dots and may represent Cartesian and/or non-Cartesian coordinates.

1.4.4 Discrete and Continuous Systems

A large number of practical systems can be described using a finite number of degrees of freedom, such as the simple systems shown in Figs. 1.10 to 1.13. Some systems, especially those involving continuous elastic members, have an infinite number of degrees of freedom. As a simple example, consider the cantilever beam shown in Fig. 1.14. Since the beam has an infinite number of mass points, we need an infinite number of coordinates to specify its deflected configuration. The infinite number of coordinates defines its elastic deflection curve. Thus the cantilever beam has an infinite number of degrees of freedom. Most structural and machine systems have deformable (elastic) members and therefore have an infinite number of degrees of freedom.

Systems with a finite number of degrees of freedom are called *discrete* or *lumped parameter* systems, and those with an infinite number of degrees of freedom are called *continuous* or *distributed* systems.

Most of the time, continuous systems are approximated as discrete systems, and solutions are obtained in a simpler manner. Although treatment of a system as continuous gives exact results, the analytical methods available for dealing with continuous systems are limited to a narrow selection of problems, such as uniform beams, slender rods, and thin plates. Hence most of the practical systems are studied by treating them as finite lumped masses, springs, and dampers. In general, more accurate results are obtained by increasing the number of masses, springs, and dampers—that is, by increasing the number of degrees of freedom.

1.5 Classification of Vibration

Vibration can be classified in several ways. Some of the important classifications are as follows.

1.5.1 Free and Forced Vibration

Free Vibration. If a system, after an initial disturbance, is left to vibrate on its own, the ensuing vibration is known as *free vibration*. No external force acts on the system. The oscillation of a simple pendulum is an example of free vibration.

Forced Vibration. If a system is subjected to an external force (often, a repeating type of force), the resulting vibration is known as *forced vibration*. The oscillation that arises in machines such as diesel engines is an example of forced vibration.

If the frequency of the external force coincides with one of the natural frequencies of the system, a condition known as *resonance* occurs, and the system undergoes dangerously large oscillations. Failures of such structures as buildings, bridges, turbines, and airplane wings have been associated with the occurrence of resonance.

1.5.2 Undamped and Damped Vibration

If no energy is lost or dissipated in friction or other resistance during oscillation, the vibration is known as *undamped vibration*. If any energy is lost in this way, however, it is called *damped vibration*. In many physical systems, the amount of damping is so small that it can be disregarded for most engineering purposes. However, consideration of damping becomes extremely important in analyzing vibratory systems near resonance.

1.5.3 Linear and Nonlinear Vibration

If all the basic components of a vibratory system—the spring, the mass, and the damper—behave linearly, the resulting vibration is known as *linear vibration*. If, however, any of the basic components behave nonlinearly, the vibration is called *nonlinear vibration*. The differential equations that govern the behavior of linear and nonlinear vibratory systems are linear and nonlinear, respectively. If the vibration is linear, the principle of superposition holds, and the mathematical techniques of analysis are well developed. For nonlinear vibration, the superposition principle is not valid, and techniques of analysis are less well known. Since all vibratory systems tend to behave nonlinearly with increasing amplitude of oscillation, a knowledge of nonlinear vibration is desirable in dealing with practical vibratory systems.

1.5.4 Deterministic and Random Vibration

If the value or magnitude of the excitation (force or motion) acting on a vibratory system is known at any given time, the excitation is called *deterministic*. The resulting vibration is known as *deterministic vibration*.

In some cases, the excitation is *nondeterministic* or *random*; the value of the excitation at a given time cannot be predicted. In these cases, a large collection of records of the excitation may exhibit some statistical regularity. It is possible to estimate averages such as the mean and mean square values of the excitation. Examples of random excitations are wind velocity, road roughness, and ground motion during earthquakes. If the excitation is random, the resulting vibration is called *random vibration*. In this case the vibratory response of the system is also random; it can be described only in terms of statistical quantities. Figure 1.15 shows examples of deterministic and random excitations.

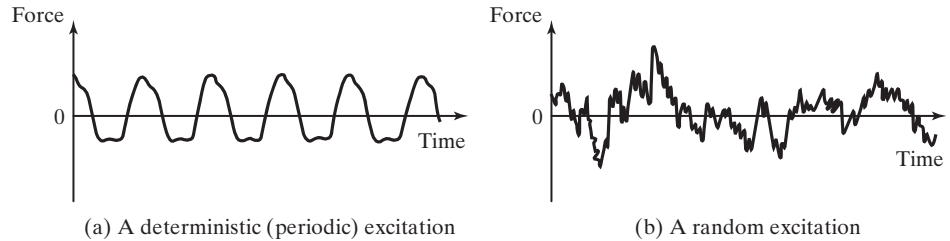

FIGURE 1.15 Deterministic and random excitations.

1.6 Vibration Analysis Procedure

A vibratory system is a dynamic one for which the variables such as the excitations (inputs) and responses (outputs) are time dependent. The response of a vibrating system generally depends on the initial conditions as well as the external excitations. Most practical vibrating systems are very complex, and it is impossible to consider all the details for a mathematical analysis. Only the most important features are considered in the analysis to predict the behavior of the system under specified input conditions. Often the overall behavior of the system can be determined by considering even a simple model of the complex physical system. Thus the analysis of a vibrating system usually involves mathematical modeling, derivation of the governing equations, solution of the equations, and interpretation of the results.

Step 1: Mathematical Modeling. The purpose of mathematical modeling is to represent all the important features of the system for the purpose of deriving the mathematical (or analytical) equations governing the system's behavior. The mathematical model should include enough details to allow describing the system in terms of equations without making it too complex. The mathematical model may be linear or nonlinear, depending on the behavior of the system's components. Linear models permit quick solutions and are simple to handle; however, nonlinear models sometimes reveal certain characteristics of the system that cannot be predicted using linear models. Thus a great deal of engineering judgment is needed to come up with a suitable mathematical model of a vibrating system.

Sometimes the mathematical model is gradually improved to obtain more accurate results. In this approach, first a very crude or elementary model is used to get a quick insight into the overall behavior of the system. Subsequently, the model is refined by including more components and/or details so that the behavior of the system can be observed more closely. To illustrate the procedure of refinement used in mathematical modeling, consider the forging hammer shown in Fig. 1.16(a). It consists of a frame, a falling weight known as the tup, an anvil, and a foundation block. The anvil is a massive steel block on which material is forged into desired shape by the repeated blows of the tup. The anvil is usually mounted on an elastic pad to reduce the transmission of vibration to the foundation block and the frame [1.22]. For a first approximation, the frame, anvil, elastic pad, foundation block, and soil are modeled as a single-degree of freedom system as shown in Fig. 1.16(b). For a refined approximation, the weights of the frame and anvil and

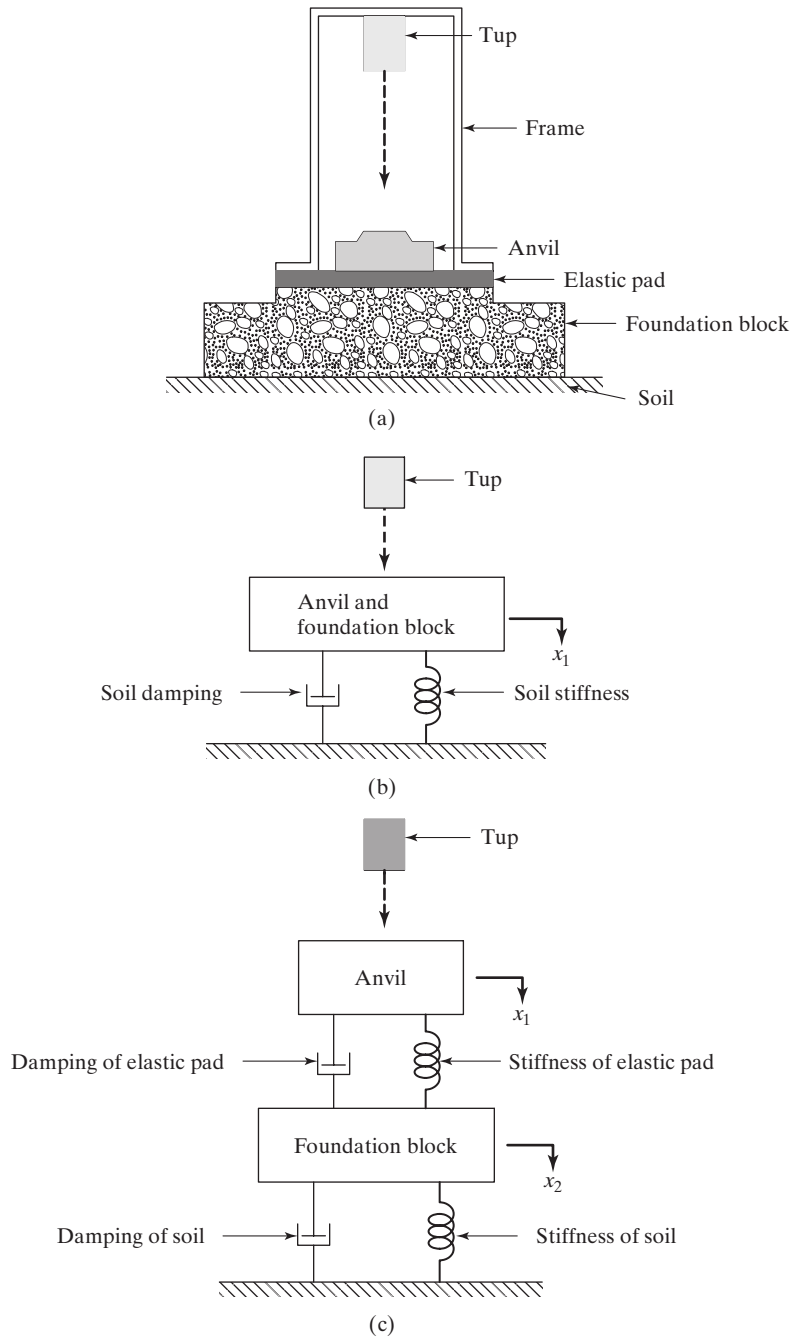

FIGURE 1.16 Modeling of a forging hammer.

the foundation block are represented separately with a two-degree-of-freedom model as shown in Fig. 1.16(c). Further refinement of the model can be made by considering eccentric impacts of the tup, which cause each of the masses shown in Fig. 1.16(c) to have both vertical and rocking (rotation) motions in the plane of the paper.

Step 2: Derivation of Governing Equations. Once the mathematical model is available, we use the principles of dynamics and derive the equations that describe the vibration of the system. The equations of motion can be derived conveniently by drawing the free-body diagrams of all the masses involved. The free-body diagram of a mass can be obtained by isolating the mass and indicating all externally applied forces, the reactive forces, and the inertia forces. The equations of motion of a vibrating system are usually in the form of a set of ordinary differential equations for a discrete system and partial differential equations for a continuous system. The equations may be linear or nonlinear, depending on the behavior of the components of the system. Several approaches are commonly used to derive the governing equations. Among them are Newton's second law of motion, D'Alembert's principle, and the principle of conservation of energy.

Step 3: Solution of the Governing Equations. The equations of motion must be solved to find the response of the vibrating system. Depending on the nature of the problem, we can use one of the following techniques for finding the solution: standard methods of solving differential equations, Laplace transform methods, matrix methods,¹ and numerical methods. If the governing equations are nonlinear, they can seldom be solved in closed form. Furthermore, the solution of partial differential equations is far more involved than that of ordinary differential equations. Numerical methods involving computers can be used to solve the equations. However, it will be difficult to draw general conclusions about the behavior of the system using computer results.

Step 4: Interpretation of the Results. The solution of the governing equations gives the displacements, velocities, and accelerations of the various masses of the system. These results must be interpreted with a clear view of the purpose of the analysis and the possible design implications of the results.

EXAMPLE 1.1

Mathematical Model of a Motorcycle

Figure 1.17(a) shows a motorcycle with a rider. Develop a sequence of three mathematical models of the system for investigating vibration in the vertical direction. Consider the elasticity of the tires, elasticity and damping of the struts (in the vertical direction), masses of the wheels, and elasticity, damping, and mass of the rider.

Solution: We start with the simplest model and refine it gradually. When the equivalent values of the mass, stiffness, and damping of the system are used, we obtain a single-degree-of-freedom model

¹The basic definitions and operations of matrix theory are given in Appendix A.

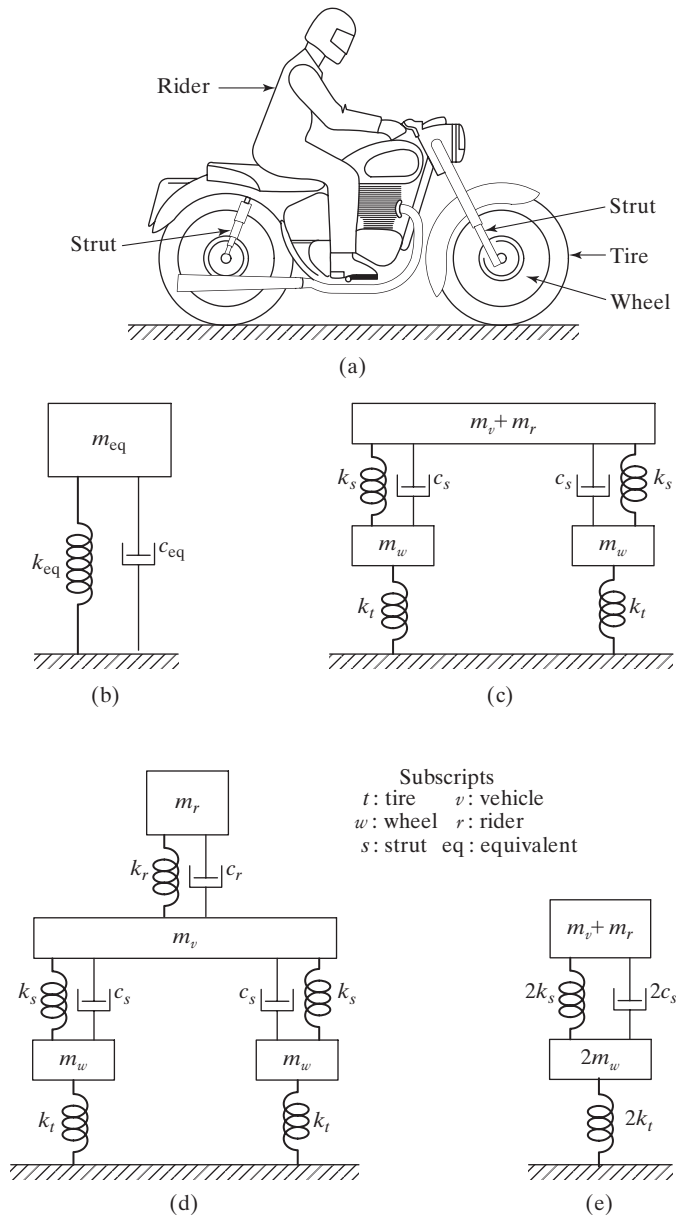

FIGURE 1.17 Motorcycle with a rider—a physical system and mathematical model.

of the motorcycle with a rider as indicated in Fig. 1.17(b). In this model, the equivalent stiffness (k_{eq}) includes the stiffnesses of the tires, struts, and rider. The equivalent damping constant (c_{eq}) includes the damping of the struts and the rider. The equivalent mass includes the masses of the wheels, vehicle body, and the rider. This model can be refined by representing the masses of wheels,

elasticity of the tires, and elasticity and damping of the struts separately, as shown in Fig. 1.17(c). In this model, the mass of the vehicle body (m_v) and the mass of the rider (m_r) are shown as a single mass, $m_v + m_r$. When the elasticity (as spring constant k_r) and damping (as damping constant c_r) of the rider are considered, the refined model shown in Fig. 1.17(d) can be obtained.

Note that the models shown in Figs. 1.17(b) to (d) are not unique. For example, by combining the spring constants of both tires, the masses of both wheels, and the spring and damping constants of both struts as single quantities, the model shown in Fig. 1.17(e) can be obtained instead of Fig. 1.17(c).

1.7 Spring Elements

A spring is a type of mechanical link, which in most applications is assumed to have negligible mass and damping. The most common type of spring is the helical-coil spring used in retractable pens and pencils, staplers, and suspensions of freight trucks and other vehicles. Several other types of springs can be identified in engineering applications. In fact, any elastic or deformable body or member, such as a cable, bar, beam, shaft or plate, can be considered as a spring. A spring is commonly represented as shown in Fig. 1.18(a). If the free length of the spring, with no forces acting, is denoted l , it undergoes a change in length when an axial force is applied. For example, when a tensile force F is applied at its free end 2, the spring undergoes an elongation x as shown in Fig. 1.18(b), while a compressive force F applied at the free end 2 causes a reduction in length x as shown in Fig. 1.18(c).

A spring is said to be linear if the elongation or reduction in length x is related to the applied force F as

$$F = kx \quad (1.1)$$

where k is a constant, known as the *spring constant* or *spring stiffness* or *spring rate*. The spring constant k is always positive and denotes the force (positive or negative) required to

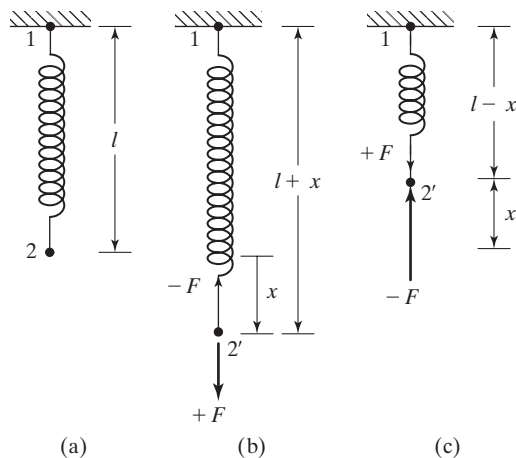

FIGURE 1.18 Deformation of a spring.

cause a unit deflection (elongation or reduction in length) in the spring. When the spring is stretched (or compressed) under a tensile (or compressive) force F , according to Newton's third law of motion, a restoring force or reaction of magnitude $-F$ (or $+F$) is developed opposite to the applied force. This restoring force tries to bring the stretched (or compressed) spring back to its original unstretched or free length as shown in Fig. 1.18(b) (or 1.18(c)). If we plot a graph between F and x , the result is a straight line according to Eq. (1.1). The work done (U) in deforming a spring is stored as strain or potential energy in the spring, and it is given by

$$U = \frac{1}{2}kx^2 \quad (1.2)$$

1.7.1 Nonlinear Springs

Most springs used in practical systems exhibit a nonlinear force-deflection relation, particularly when the deflections are large. If a nonlinear spring undergoes small deflections, it can be replaced by a linear spring by using the procedure discussed in Section 1.7.2. In vibration analysis, nonlinear springs whose force-deflection relations are given by

$$F = ax + bx^3; \quad a > 0 \quad (1.3)$$

are commonly used. In Eq. (1.3), a denotes the constant associated with the linear part and b indicates the constant associated with the (cubic) nonlinearity. The spring is said to be hard if $b > 0$, linear if $b = 0$, and soft if $b < 0$. The force-deflection relations for various values of b are shown in Fig. 1.19.

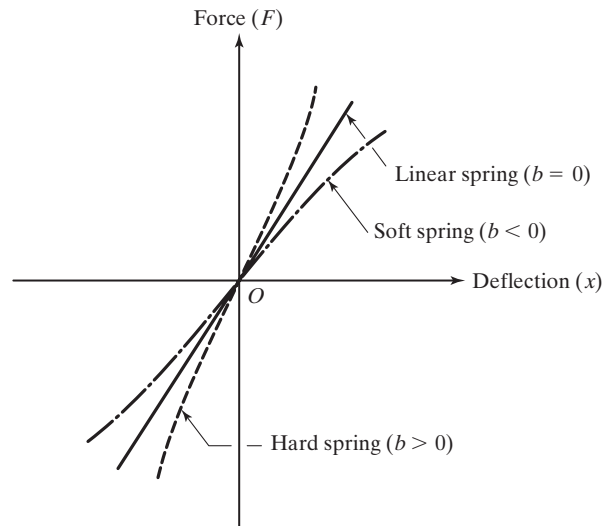

FIGURE 1.19 Nonlinear and linear springs.

Some systems, involving two or more springs, may exhibit a nonlinear force-displacement relationship although the individual springs are linear. Some examples of such systems are shown in Figs. 1.20 and 1.21. In Fig. 1.20(a), the weight (or force) W travels

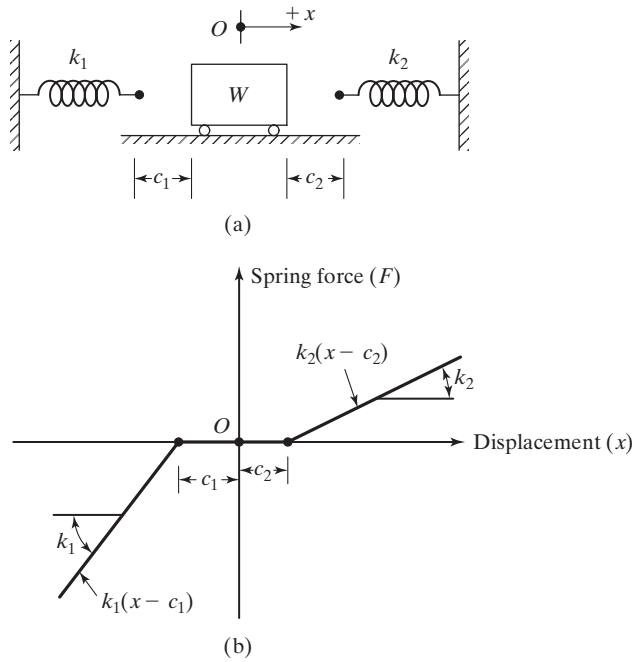

FIGURE 1.20 Nonlinear spring force-displacement relation.

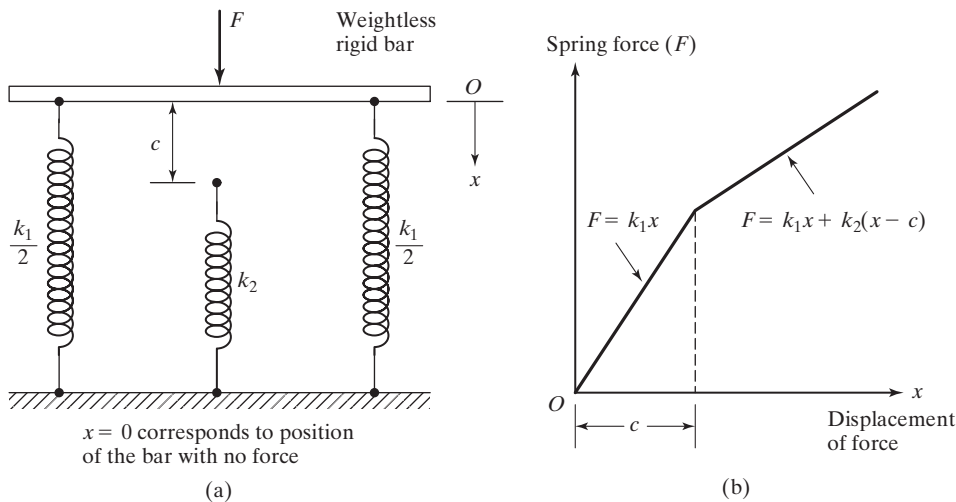

FIGURE 1.21 Nonlinear spring force-displacement relation.

freely through the clearances c_1 and c_2 present in the system. Once the weight comes into contact with a particular spring, after passing through the corresponding clearance, the spring force increases in proportion to the spring constant of the particular spring (see Fig. 1.20(b)). It can be seen that the resulting force-displacement relation, although piecewise linear, denotes a nonlinear relationship.

In Fig. 1.21(a), the two springs, with stiffnesses k_1 and k_2 , have different lengths. Note that the spring with stiffness k_1 is shown, for simplicity, in the form of two parallel springs, each with a stiffness of $k_1/2$. Spring arrangement models of this type can be used in the vibration analysis of packages and suspensions used in aircraft landing gears.

When the spring k_1 deflects by an amount $x = c$, the second spring starts providing an additional stiffness k_2 to the system. The resulting nonlinear force-displacement relationship is shown in Fig. 1.21(b).

1.7.2 Linearization of a Nonlinear Spring

Actual springs are nonlinear and follow Eq. (1.1) only up to a certain deformation. Beyond a certain value of deformation (after point A in Fig. 1.22), the stress exceeds the yield point of the material and the force-deformation relation becomes nonlinear [1.23, 1.24]. In many practical applications we assume that the deflections are small and make use of the linear relation in Eq. (1.1). Even, if the force-deflection relation of a spring is nonlinear, as shown in Fig. 1.23, we often approximate it as a linear one by using a linearization process [1.24, 1.25]. To illustrate the linearization process, let the static equilibrium load F acting on the spring cause a deflection of x^* . If an incremental force ΔF is added to F , the spring deflects by an additional quantity Δx . The new spring force $F + \Delta F$ can be expressed using Taylor's series expansion about the static equilibrium position x^* as

$$\begin{aligned} F + \Delta F &= F(x^* + \Delta x) \\ &= F(x^*) + \left. \frac{dF}{dx} \right|_{x^*} (\Delta x) + \frac{1}{2!} \left. \frac{d^2F}{dx^2} \right|_{x^*} (\Delta x)^2 + \dots \end{aligned} \quad (1.4)$$

For small values of Δx , the higher-order derivative terms can be neglected to obtain

$$F + \Delta F = F(x^*) + \left. \frac{dF}{dx} \right|_{x^*} (\Delta x) \quad (1.5)$$

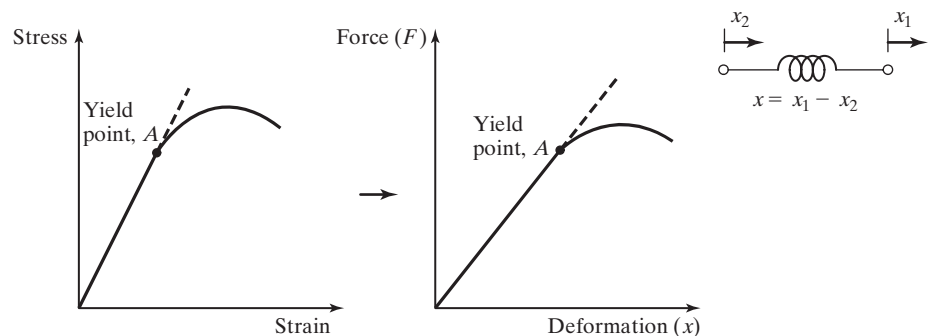

FIGURE 1.22 Nonlinearity beyond proportionality limit.

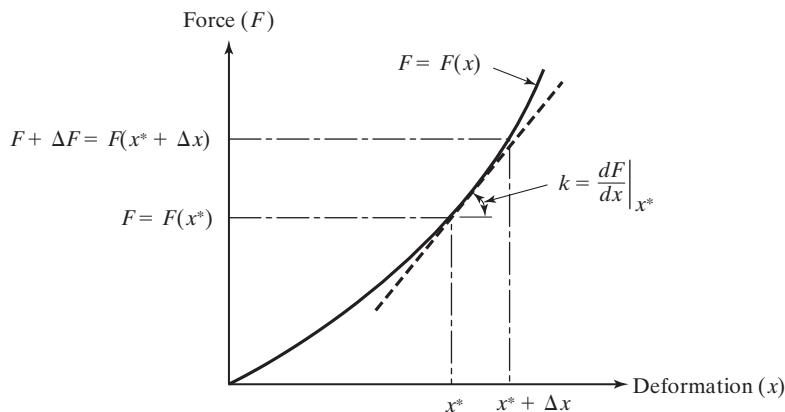

FIGURE 1.23 Linearization process.

Since $F = F(x^*)$, we can express ΔF as

$$\Delta F = k \Delta x \quad (1.6)$$

where k is the linearized spring constant at x^* given by

$$k = \left. \frac{dF}{dx} \right|_{x^*} \quad (1.7)$$

We may use Eq. (1.6) for simplicity, but sometimes the error involved in the approximation may be very large.

EXAMPLE 1.2

Equivalent Linearized Spring Constant

A precision milling machine, weighing 1000 lb, is supported on a rubber mount. The force-deflection relationship of the rubber mount is given by

$$F = 2000x + 200x^3 \quad (E.1)$$

where the force (F) and the deflection (x) are measured in pounds and inches, respectively. Determine the equivalent linearized spring constant of the rubber mount at its static equilibrium position.

Solution: The static equilibrium position of the rubber mount (x^*), under the weight of the milling machine, can be determined from Eq. (E.1):

$$1000 = 2000x^* + 200(x^*)^3$$

or

$$200(x^*)^3 + 2000x^* - 1000 = 0 \quad (E.2)$$

The roots of the cubic equation, (E.2), can be found (for example, using the function *roots* in MATLAB) as

$$x^* = 0.4884, \quad -0.2442 + 3.1904i, \quad \text{and} \quad -0.2442 - 3.1904i$$

The static equilibrium position of the rubber mount is given by the real root of Eq. (E.2): $x^* = 0.4884$ in. The equivalent linear spring constant of the rubber mount at its static equilibrium position can be determined using Eq. (1.7):

$$k_{eq} = \left. \frac{dF}{dx} \right|_{x^*} = 2000 + 600(x^*)^2 = 2000 + 600(0.4884^2) = 2143.1207 \text{ lb/in.}$$

Note: The equivalent linear spring constant, $k_{eq} = 2143.1207$ lb/in., predicts the static deflection of the milling machine as

$$x = \frac{F}{k_{eq}} = \frac{1000}{2143.1207} = 0.4666 \text{ in.}$$

which is slightly different from the true value of 0.4884 in. The error is due to the truncation of the higher-order derivative terms in Eq. (1.4). ■

1.7.3 Spring Constants of Elastic Elements

As stated earlier, any elastic or deformable member (or element) can be considered as a spring. The equivalent spring constants of simple elastic members such as rods, beams, and hollow shafts are given on the inside front cover of the book. The procedure of finding the equivalent spring constant of elastic members is illustrated through the following examples.

EXAMPLE 1.3

Spring Constant of a Rod

Find the equivalent spring constant of a uniform rod of length l , cross-sectional area A , and Young's modulus E subjected to an axial tensile (or compressive) force F as shown in Fig. 1.24(a).

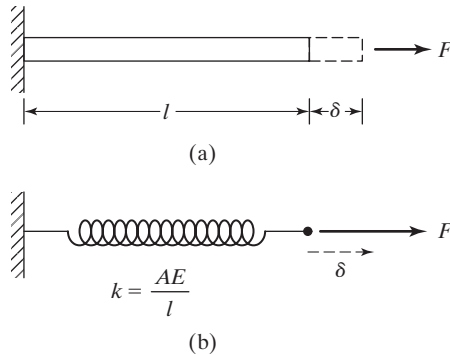

FIGURE 1.24 Spring constant of a rod.

Solution: The elongation (or shortening) δ of the rod under the axial tensile (or compressive) force F can be expressed as

$$\delta = \frac{\delta}{l} l = \epsilon l = \frac{\sigma}{E} l = \frac{Fl}{AE} \quad (\text{E.1})$$

where $\epsilon = \frac{\text{change in length}}{\text{original length}} = \frac{\delta}{l}$ is the strain and $\sigma = \frac{\text{force}}{\text{area}} = \frac{F}{A}$ is the stress induced in the rod. Using the definition of the spring constant k , we obtain from Eq. (E.1):

$$k = \frac{\text{force applied}}{\text{resulting deflection}} = \frac{F}{\delta} = \frac{AE}{l} \quad (\text{E.2})$$

The significance of the equivalent spring constant of the rod is shown in Fig. 1.24(b). ■

EXAMPLE 1.4

Spring Constant of a Cantilever Beam

Find the equivalent spring constant of a cantilever beam subjected to a concentrated load F at its end as shown in Fig. 1.25(a).

Solution: We assume, for simplicity, that the self weight (or mass) of the beam is negligible and the concentrated load F is due to the weight of a point mass ($W = mg$). From strength of materials [1.26], we know that the end deflection of the beam due to a concentrated load $F = W$ is given by

$$\delta = \frac{Wl^3}{3EI} \quad (\text{E.1})$$

where E is the Young's modulus and I is the moment of inertia of the cross section of the beam about the bending or z -axis (i.e., axis perpendicular to the page). Hence the spring constant of the beam is (Fig. 1.25(b)):

$$k = \frac{W}{\delta} = \frac{3EI}{l^3} \quad (\text{E.2})$$

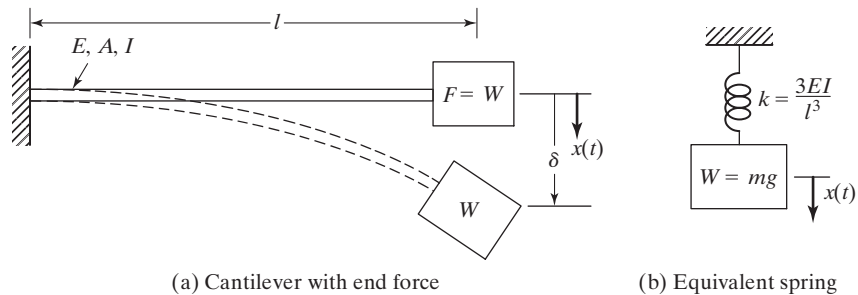

FIGURE 1.25 Spring constant of a cantilever beam.

Notes:

1. It is possible for a cantilever beam to be subjected to concentrated loads in two directions at its end—one in the y direction (F_y) and the other in the z direction (F_z)—as shown in Fig. 1.26(a). When the load is applied along the y direction, the beam bends about the z -axis (Fig. 1.26(b)) and hence the equivalent spring constant will be equal to

$$k = \frac{3EI_{zz}}{l^3} \quad (\text{E.3})$$

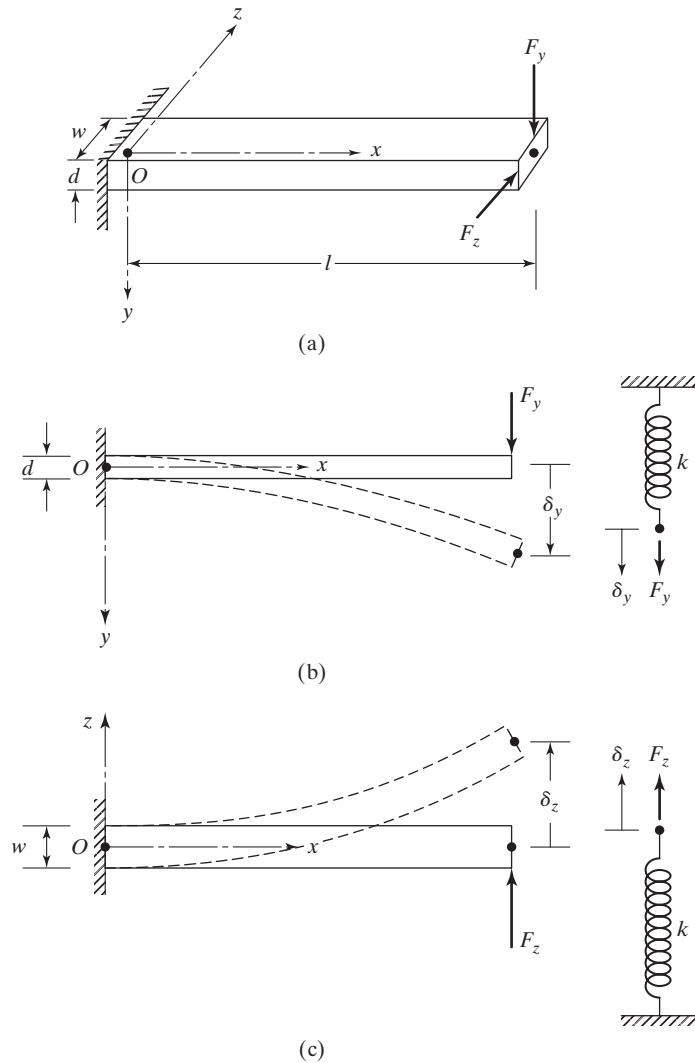

FIGURE 1.26 Spring constants of a beam in two directions.

When the load is applied along the z direction, the beam bends about the y -axis (Fig. 1.26(c)) and hence the equivalent spring constant will be equal to

$$k = \frac{3EI_{yy}}{l^3} \tag{E.4}$$

- The spring constants of beams with different end conditions can be found in a similar manner using results from strength of materials. The representative formulas given in Appendix B can be used to find the spring constants of the indicated beams and plates. For example, to find the spring constant of a fixed-fixed beam subjected to a concentrated force P at $x = a$ (Case 3 in Appendix B), first we express the deflection of the beam at the load point ($x = a$), using $b = l - a$, as

$$y = \frac{P(l - a)^2 a^2}{6EI l^3} [3al - 3a^2 - a(l - a)] = \frac{Pa^2(l - a)^2(al - a^2)}{3EI l^3} \tag{E.5}$$

and then find the spring constant (k) as

$$k = \frac{P}{y} = \frac{3EI l^3}{a^2(l - a)^2(al - a^2)} \tag{E.6}$$

where $I = I_{zz}$.

- The effect of the self weight (or mass) of the beam can also be included in finding the spring constant of the beam (see Example 2.9 in Chapter 2).

■

1.7.4 Combination of Springs

In many practical applications, several linear springs are used in combination. These springs can be combined into a single equivalent spring as indicated below.

Case 1: Springs in Parallel. To derive an expression for the equivalent spring constant of springs connected in parallel, consider the two springs shown in Fig. 1.27(a). When a load W is applied, the system undergoes a static deflection δ_{st} as shown in Fig. 1.27(b). Then the free-body diagram, shown in Fig. 1.27(c), gives the equilibrium equation

$$W = k_1 \delta_{st} + k_2 \delta_{st} \tag{1.8}$$

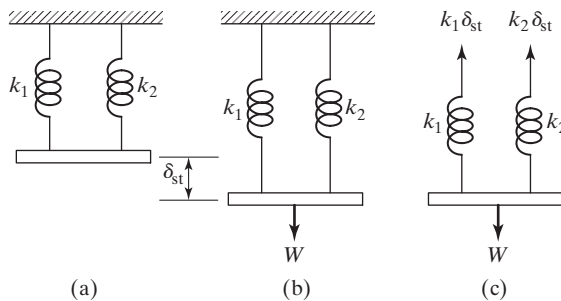

FIGURE 1.27 Springs in parallel.

If k_{eq} denotes the equivalent spring constant of the combination of the two springs, then for the same static deflection δ_{st} we have

$$W = k_{\text{eq}}\delta_{\text{st}} \quad (1.9)$$

Equations (1.8) and (1.9) give

$$k_{\text{eq}} = k_1 + k_2 \quad (1.10)$$

In general, if we have n springs with spring constants k_1, k_2, \dots, k_n in parallel, then the equivalent spring constant k_{eq} can be obtained:

$$k_{\text{eq}} = k_1 + k_2 + \dots + k_n \quad (1.11)$$

Case 2: Springs in Series. Next we derive an expression for the equivalent spring constant of springs connected in series by considering the two springs shown in Fig. 1.28(a). Under the action of a load W , springs 1 and 2 undergo elongations δ_1 and δ_2 , respectively, as shown in Fig. 1.28(b). The total elongation (or static deflection) of the system, δ_{st} is given by

$$\delta_{\text{st}} = \delta_1 + \delta_2 \quad (1.12)$$

Since both springs are subjected to the same force W , we have the equilibrium shown in Fig. 1.28(c):

$$\begin{aligned} W &= k_1\delta_1 \\ W &= k_2\delta_2 \end{aligned} \quad (1.13)$$

If k_{eq} denotes the equivalent spring constant, then for the same static deflection,

$$W = k_{\text{eq}}\delta_{\text{st}} \quad (1.14)$$

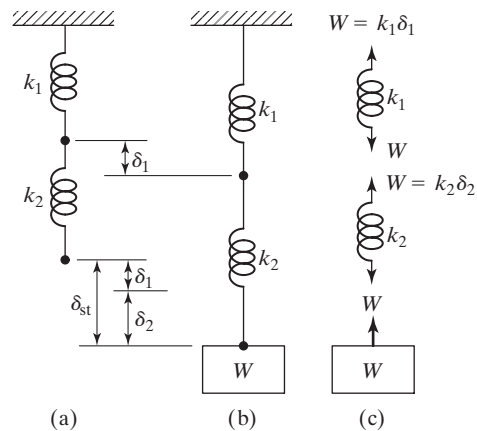

FIGURE 1.28 Springs in series.

Equations (1.13) and (1.14) give

$$k_1\delta_1 = k_2\delta_2 = k_{\text{eq}}\delta_{\text{st}}$$

or

$$\delta_1 = \frac{k_{\text{eq}}\delta_{\text{st}}}{k_1} \quad \text{and} \quad \delta_2 = \frac{k_{\text{eq}}\delta_{\text{st}}}{k_2} \quad (1.15)$$

Substituting these values of δ_1 and δ_2 into Eq. (1.12), we obtain

$$\frac{k_{\text{eq}}\delta_{\text{st}}}{k_1} + \frac{k_{\text{eq}}\delta_{\text{st}}}{k_2} = \delta_{\text{st}}$$

—that is,

$$\frac{1}{k_{\text{eq}}} = \frac{1}{k_1} + \frac{1}{k_2} \quad (1.16)$$

Equation (1.16) can be generalized to the case of n springs in series:

$$\frac{1}{k_{\text{eq}}} = \frac{1}{k_1} + \frac{1}{k_2} + \cdots + \frac{1}{k_n} \quad (1.17)$$

In certain applications, springs are connected to rigid components such as pulleys, levers, and gears. In such cases, an equivalent spring constant can be found using energy equivalence, as illustrated in Examples 1.8 and 1.9.

EXAMPLE 1.5

Equivalent k of a Suspension System

Figure 1.29 shows the suspension system of a freight truck with a parallel-spring arrangement. Find the equivalent spring constant of the suspension if each of the three helical springs is made of steel with a shear modulus $G = 80 \times 10^9 \text{ N/m}^2$ and has five effective turns, mean coil diameter $D = 20 \text{ cm}$, and wire diameter $d = 2 \text{ cm}$.

Solution: The stiffness of each helical spring is given by

$$k = \frac{d^4 G}{8D^3 n} = \frac{(0.02)^4 (80 \times 10^9)}{8(0.2)^3 (5)} = 40,000.0 \text{ N/m}$$

(See inside front cover for the formula.)

Since the three springs are identical and parallel, the equivalent spring constant of the suspension system is given by

$$k_{\text{eq}} = 3k = 3(40,000.0) = 120,000.0 \text{ N/m}$$

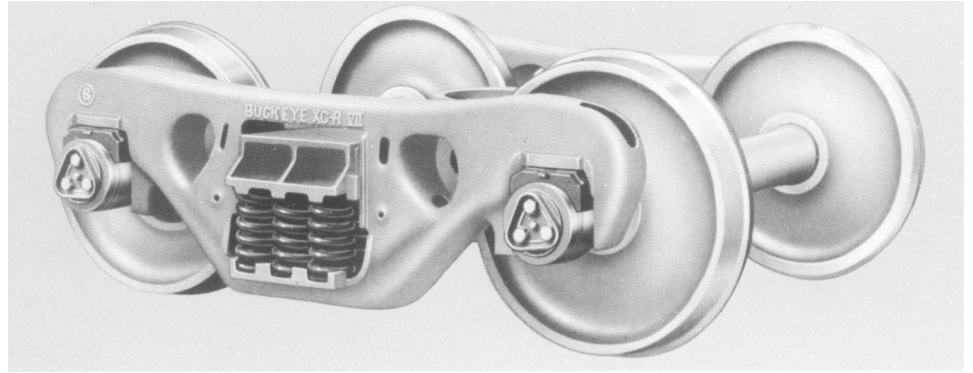

FIGURE 1.29 Parallel arrangement of springs in a freight truck. (Courtesy of Buckeye Steel Castings Company.)

■

EXAMPLE 1.6

Torsional Spring Constant of a Propeller Shaft

Determine the torsional spring constant of the steel propeller shaft shown in Fig. 1.30.

Solution: We need to consider the segments 12 and 23 of the shaft as springs in combination. From Fig. 1.30 the torque induced at any cross section of the shaft (such as AA or BB) can be seen to be

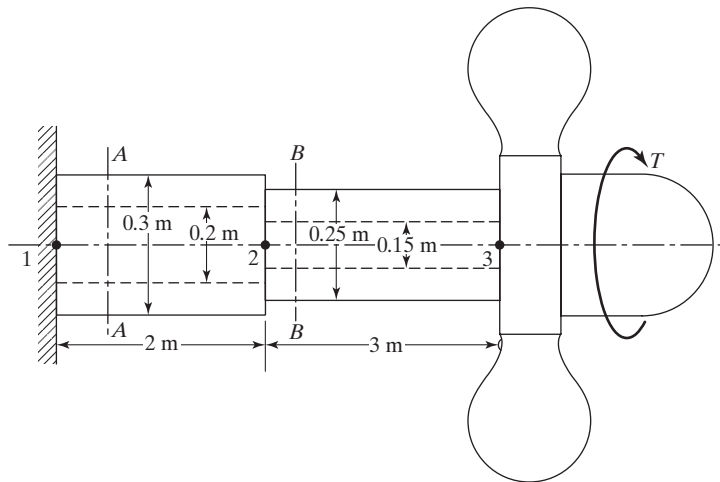

FIGURE 1.30 Propeller shaft.

equal to the torque applied at the propeller, T . Hence the elasticities (springs) corresponding to the two segments 12 and 23 are to be considered as series springs. The spring constants of segments 12 and 23 of the shaft ($k_{t_{12}}$ and $k_{t_{23}}$) are given by

$$\begin{aligned} k_{t_{12}} &= \frac{GJ_{12}}{l_{12}} = \frac{G\pi(D_{12}^4 - d_{12}^4)}{32l_{12}} = \frac{(80 \times 10^9)\pi(0.3^4 - 0.2^4)}{32(2)} \\ &= 25.5255 \times 10^6 \text{ N-m/rad} \\ k_{t_{23}} &= \frac{GJ_{23}}{l_{23}} = \frac{G\pi(D_{23}^4 - d_{23}^4)}{32l_{23}} = \frac{(80 \times 10^9)\pi(0.25^4 - 0.15^4)}{32(3)} \\ &= 8.9012 \times 10^6 \text{ N-m/rad} \end{aligned}$$

Since the springs are in series, Eq. (1.16) gives

$$k_{t_{eq}} = \frac{k_{t_{12}}k_{t_{23}}}{k_{t_{12}} + k_{t_{23}}} = \frac{(25.5255 \times 10^6)(8.9012 \times 10^6)}{(25.5255 \times 10^6 + 8.9012 \times 10^6)} = 6.5997 \times 10^6 \text{ N-m/rad}$$

■

EXAMPLE 1.7

Equivalent k of Hoisting Drum

A hoisting drum, carrying a steel wire rope, is mounted at the end of a cantilever beam as shown in Fig. 1.31 (a). Determine the equivalent spring constant of the system when the suspended length of the wire rope is l . Assume that the net cross-sectional diameter of the wire rope is d and the Young's modulus of the beam and the wire rope is E .

Solution: The spring constant of the cantilever beam is given by

$$k_b = \frac{3EI}{b^3} = \frac{3E}{b^3} \left(\frac{1}{12} at^3 \right) = \frac{Eat^3}{4b^3} \tag{E.1}$$

The stiffness of the wire rope subjected to axial loading is

$$k_r = \frac{AE}{l} = \frac{\pi d^2 E}{4l} \tag{E.2}$$

Since both the wire rope and the cantilever beam experience the same load W , as shown in Fig. 1.31 (b), they can be modeled as springs in series, as shown in Fig. 1.31 (c). The equivalent spring constant k_{eq} is given by

$$\frac{1}{k_{eq}} = \frac{1}{k_b} + \frac{1}{k_r} = \frac{4b^3}{Eat^3} + \frac{4l}{\pi d^2 E}$$

or

$$k_{eq} = \frac{E}{4} \left(\frac{\pi at^3 d^2}{\pi d^2 b^3 + lat^3} \right) \tag{E.3}$$

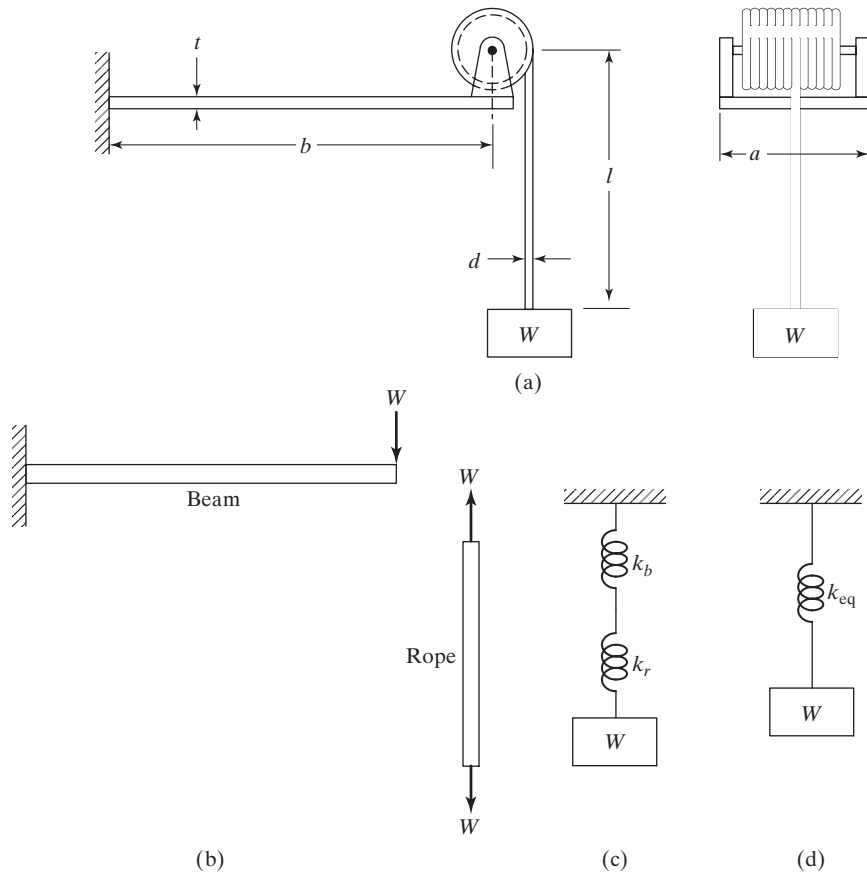

FIGURE 1.31 Hoisting drum.

EXAMPLE 1.8**Equivalent k of a Crane**

The boom AB of the crane shown in Fig. 1.32(a) is a uniform steel bar of length 10 m and area of cross section $2,500 \text{ mm}^2$. A weight W is suspended while the crane is stationary. The cable $CDEBF$ is made of steel and has a cross-sectional area of 100 mm^2 . Neglecting the effect of the cable $CDEB$, find the equivalent spring constant of the system in the vertical direction.

Solution: The equivalent spring constant can be found using the equivalence of potential energies of the two systems. Since the base of the crane is rigid, the cable and the boom can be considered to be fixed at points F and A , respectively. Also, the effect of the cable $CDEB$ is negligible; hence the weight W can be assumed to act through point B as shown in Fig. 1.32(b).

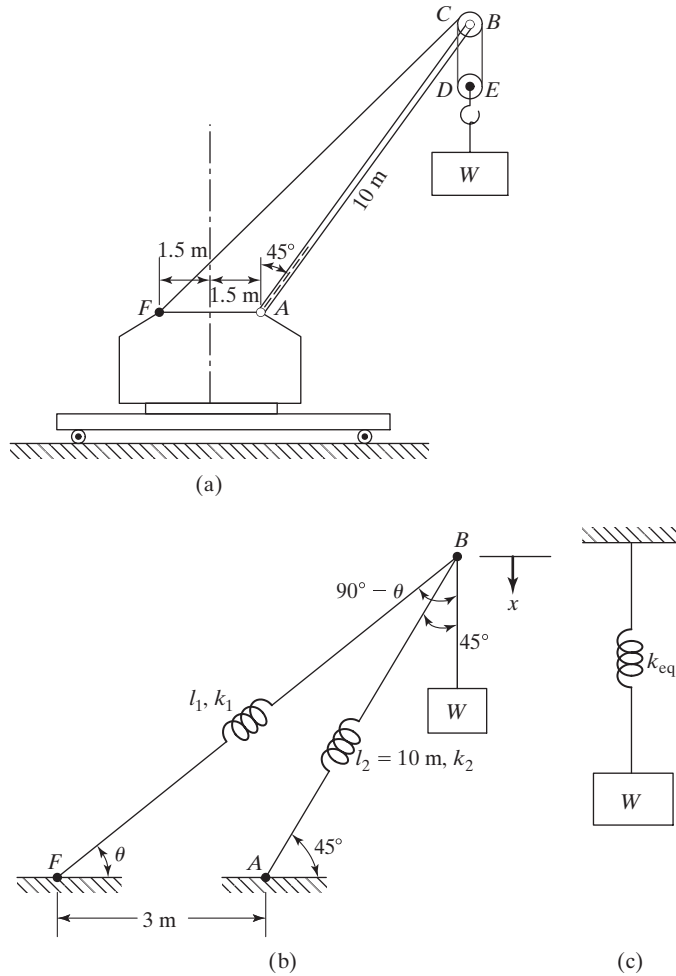

FIGURE 1.32 Crane lifting a load.

A vertical displacement x of point B will cause the spring (boom) to deform by an amount and the spring (cable) to deform by an amount. The length of the cable FB , l_1 , is given by Fig. 1.32(b):

$$l_1^2 = 3^2 + 10^2 - 2(3)(10) \cos 135^\circ = 151.426, \quad l_1 = 12.3055 \text{ m}$$

The angle θ satisfies the relation

$$l_1^2 + 3^2 - 2(l_1)(3) \cos \theta = 10^2, \quad \cos \theta = 0.8184, \quad \theta = 35.0736^\circ$$

The total potential energy (U) stored in the springs k_1 and k_2 can be expressed, using Eq. (1.2) as

$$U = \frac{1}{2} k_1 [x \cos (90^\circ - \theta)]^2 + \frac{1}{2} k_2 [x \cos (90^\circ - 45^\circ)]^2 \quad (\text{E.1})$$

where

$$k_1 = \frac{A_1 E_1}{l_1} = \frac{(100 \times 10^{-6})(207 \times 10^9)}{12.3055} = 1.6822 \times 10^6 \text{ N/m}$$

and

$$k_2 = \frac{A_2 E_2}{l_2} = \frac{(2500 \times 10^{-6})(207 \times 10^9)}{10} = 5.1750 \times 10^7 \text{ N/m}$$

Since the equivalent spring in the vertical direction undergoes a deformation x , the potential energy of the equivalent spring (U_{eq}) is given by

$$U_{\text{eq}} = \frac{1}{2} k_{\text{eq}} x^2 \quad (\text{E.2})$$

By setting $U = U_{\text{eq}}$, we obtain the equivalent spring constant of the system as

$$k_{\text{eq}} = k_1 \sin^2 \theta + k_2 \sin^2 45^\circ = k_1 \sin^2 35.0736^\circ + k_2 \sin^2 45^\circ = 26.4304 \times 10^6 \text{ N/m}$$

■

EXAMPLE 1.9

Equivalent k of a Rigid Bar Connected by Springs

A hinged rigid bar of length l is connected by two springs of stiffnesses k_1 and k_2 and is subjected to a force F as shown in Fig. 1.33(a). Assuming that the angular displacement of the bar (θ) is small, find the equivalent spring constant of the system that relates the applied force F to the resulting displacement x .

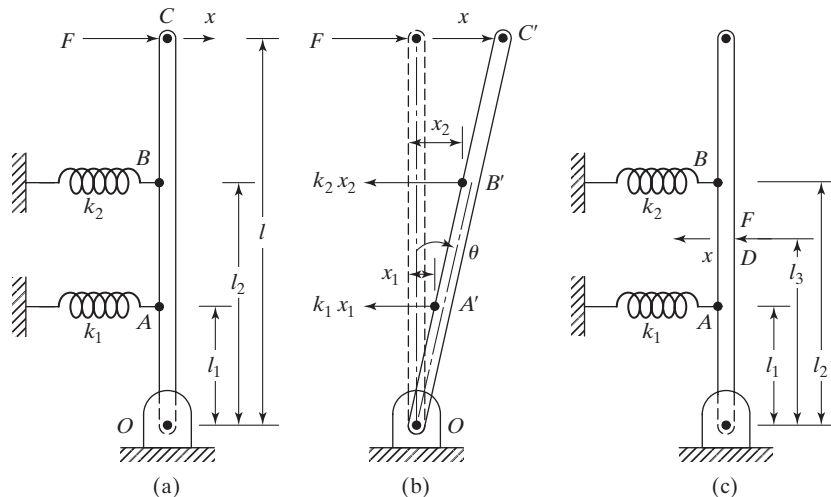

FIGURE 1.33 Rigid bar connected by springs.

Solution: For a small angular displacement of the rigid bar (θ), the points of attachment of springs k_1 and k_2 (A and B) and the point of application (C) of the force F undergo the linear or horizontal displacements $l_1 \sin \theta$, $l_2 \sin \theta$, and $l \sin \theta$, respectively. Since θ is small, the horizontal displacements of points A , B , and C can be approximated as $x_1 = l_1\theta$, $x_2 = l_2\theta$ and $x = l\theta$, respectively. The reactions of the springs, k_1x_1 and k_2x_2 , will be as indicated in Fig. 1.33(b). The equivalent spring constant of the system (k_{eq}) referred to the point of application of the force F can be determined by considering the moment equilibrium of the forces about the hinge point O :

$$k_1x_1(l_1) + k_2x_2(l_2) = F(l)$$

or

$$F = k_1\left(\frac{x_1l_1}{l}\right) + k_2\left(\frac{x_2l_2}{l}\right) \quad (\text{E.1})$$

By expressing F as $k_{\text{eq}}x$, Eq. (E.1) can be written as

$$F = k_{\text{eq}}x = k_1\left(\frac{x_1l_1}{l}\right) + k_2\left(\frac{x_2l_2}{l}\right) \quad (\text{E.2})$$

Using $x_1 = l_1\theta$, $x_2 = l_2\theta$, and $x = l\theta$, Eq. (E.2) yields the desired result:

$$k_{\text{eq}} = k_1\left(\frac{l_1}{l}\right)^2 + k_2\left(\frac{l_2}{l}\right)^2 \quad (\text{E.3})$$

Notes:

1. If the force F is applied at another point D of the rigid bar as shown in Fig. 1.33(c), the equivalent spring constant referred to point D can be found as

$$k_{\text{eq}} = k_1\left(\frac{l_1}{l_3}\right)^2 + k_2\left(\frac{l_2}{l_3}\right)^2 \quad (\text{E.4})$$

2. The equivalent spring constant, k_{eq} , of the system can also be found by using the relation:

$$\text{Work done by the applied force } F = \text{Strain energy stored in springs } k_1 \text{ and } k_2 \quad (\text{E.5})$$

For the system shown in Fig. 1.33(a), Eq. (E.5) gives

$$\frac{1}{2}Fx = \frac{1}{2}k_1x_1^2 + \frac{1}{2}k_2x_2^2 \quad (\text{E.6})$$

from which Eq. (E.3) can readily be obtained.

3. Although the two springs appear to be connected to the rigid bar in parallel, the formula of parallel springs (Eq. 1.12) cannot be used because the displacements of the two springs are not the same.

■

1.7.5 Spring Constant Associated with the Restoring Force due to Gravity

In some applications, a restoring force or moment due to gravity is developed when a mass undergoes a displacement. In such cases, an equivalent spring constant can be associated with the restoring force or moment of gravity. The following example illustrates the procedure.

EXAMPLE 1.10

Spring Constant Associated with Restoring Force due to Gravity

Figure 1.34 shows a simple pendulum of length l with a bob of mass m . Considering an angular displacement θ of the pendulum, determine the equivalent spring constant associated with the restoring force (or moment).

Solution: When the pendulum undergoes an angular displacement θ , the mass m moves by a distance $l \sin \theta$ along the horizontal (x) direction. The restoring moment or torque (T) created by the weight of the mass (mg) about the pivot point O is given by

$$T = mg(l \sin \theta) \quad (\text{E.1})$$

For small angular displacements θ , $\sin \theta$ can be approximated as $\sin \theta \approx \theta$ (see Appendix A) and Eq. (E.1) becomes

$$T = mgl\theta \quad (\text{E.2})$$

By expressing Eq. (E.2) as

$$T = k_t\theta \quad (\text{E.3})$$

the desired equivalent torsional spring constant k_t can be identified as

$$k_t = mgl \quad (\text{E.4})$$

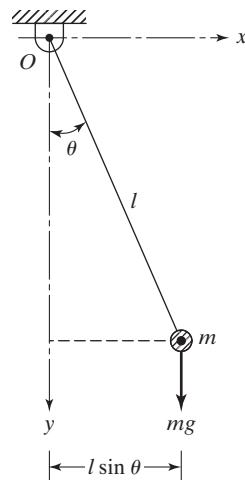

FIGURE 1.34 Simple pendulum. ■

1.8 Mass or Inertia Elements

The mass or inertia element is assumed to be a rigid body; it can gain or lose kinetic energy whenever the velocity of the body changes. From Newton's second law of motion, the product of the mass and its acceleration is equal to the force applied to the mass. Work is equal to the force multiplied by the displacement in the direction of the force, and the work done on a mass is stored in the form of the mass's kinetic energy.

In most cases, we must use a mathematical model to represent the actual vibrating system, and there are often several possible models. The purpose of the analysis often determines which mathematical model is appropriate. Once the model is chosen, the mass or inertia elements of the system can be easily identified. For example, consider again the cantilever beam with an end mass shown in Fig. 1.25(a). For a quick and reasonably accurate analysis, the mass and damping of the beam can be disregarded; the system can be modeled as a spring-mass system, as shown in Fig. 1.25(b). The tip mass m represents the mass element, and the elasticity of the beam denotes the stiffness of the spring. Next, consider a multistory building subjected to an earthquake. Assuming that the mass of the frame is negligible compared to the masses of the floors, the building can be modeled as a multi-degree-of-freedom system, as shown in Fig. 1.35. The masses at the various floor levels represent the mass elements, and the elasticities of the vertical members denote the spring elements.

1.8.1 Combination of Masses

In many practical applications, several masses appear in combination. For a simple analysis, we can replace these masses by a single equivalent mass, as indicated below [1.27].

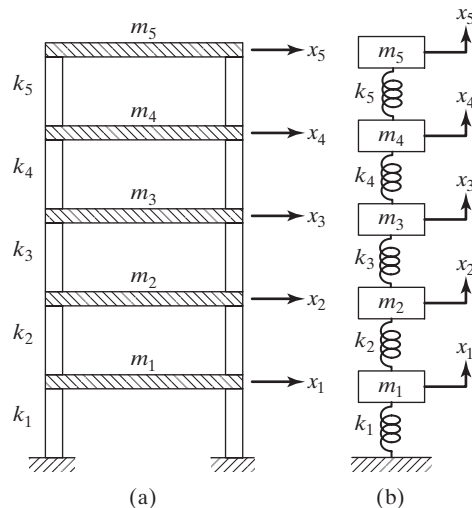

FIGURE 1.35 Idealization of a multistory building as a multi-degree-of-freedom system.

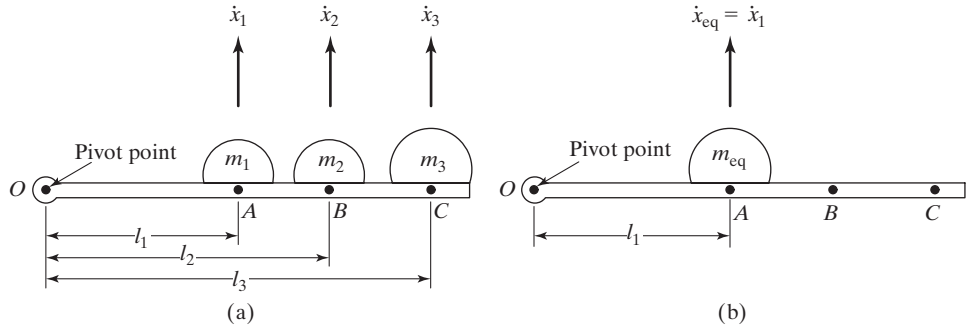

FIGURE 1.36 Translational masses connected by a rigid bar.

Case 1: Translational Masses Connected by a Rigid Bar. Let the masses be attached to a rigid bar that is pivoted at one end, as shown in Fig. 1.36(a). The equivalent mass can be assumed to be located at any point along the bar. To be specific, we assume the location of the equivalent mass to be that of mass m_1 . The velocities of masses $m_2(\dot{x}_2)$ and $m_3(\dot{x}_3)$ can be expressed in terms of the velocity of mass $m_1(\dot{x}_1)$, by assuming small angular displacements for the bar, as

$$\dot{x}_2 = \frac{l_2}{l_1}\dot{x}_1, \quad \dot{x}_3 = \frac{l_3}{l_1}\dot{x}_1 \quad (1.18)$$

and

$$\dot{x}_{\text{eq}} = \dot{x}_1 \quad (1.19)$$

By equating the kinetic energy of the three-mass system to that of the equivalent mass system, we obtain

$$\frac{1}{2}m_1\dot{x}_1^2 + \frac{1}{2}m_2\dot{x}_2^2 + \frac{1}{2}m_3\dot{x}_3^2 = \frac{1}{2}m_{\text{eq}}\dot{x}_{\text{eq}}^2 \quad (1.20)$$

This equation gives, in view of Eqs. (1.18) and (1.19):

$$m_{\text{eq}} = m_1 + \left(\frac{l_2}{l_1}\right)^2 m_2 + \left(\frac{l_3}{l_1}\right)^2 m_3 \quad (1.21)$$

It can be seen that the equivalent mass of a system composed of several masses (each moving at a different velocity) can be thought of as the imaginary mass which, while moving with a specified velocity v , will have the same kinetic energy as that of the system.

Case 2: Translational and Rotational Masses Coupled Together. Let a mass m having a translational velocity \dot{x} be coupled to another mass (of mass moment of inertia J_0) having a rotational velocity $\dot{\theta}$, as in the rack-and-pinion arrangement shown in Fig. 1.37.

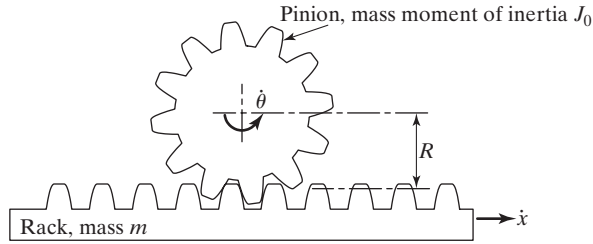

FIGURE 1.37 Translational and rotational masses in a rack-and-pinion arrangement.

These two masses can be combined to obtain either (1) a single equivalent translational mass m_{eq} or (2) a single equivalent rotational mass J_{eq} , as shown below.

1. *Equivalent translational mass.* The kinetic energy of the two masses is given by

$$T = \frac{1}{2}m\dot{x}^2 + \frac{1}{2}J_0\dot{\theta}^2 \quad (1.22)$$

and the kinetic energy of the equivalent mass can be expressed as

$$T_{\text{eq}} = \frac{1}{2}m_{\text{eq}}\dot{x}_{\text{eq}}^2 \quad (1.23)$$

Since $\dot{x}_{\text{eq}} = \dot{x}$ and $\dot{\theta} = \dot{x}/R$, the equivalence of T and T_{eq} gives

$$\frac{1}{2}m_{\text{eq}}\dot{x}^2 = \frac{1}{2}m\dot{x}^2 + \frac{1}{2}J_0\left(\frac{\dot{x}}{R}\right)^2$$

—that is,

$$m_{\text{eq}} = m + \frac{J_0}{R^2} \quad (1.24)$$

2. *Equivalent rotational mass.* Here $\dot{\theta}_{\text{eq}} = \dot{\theta}$ and $\dot{x} = \dot{\theta}R$, and the equivalence of T and T_{eq} leads to

$$\frac{1}{2}J_{\text{eq}}\dot{\theta}^2 = \frac{1}{2}m(\dot{\theta}R)^2 + \frac{1}{2}J_0\dot{\theta}^2$$

or

$$J_{\text{eq}} = J_0 + mR^2 \quad (1.25)$$

Equivalent Mass of a System

EXAMPLE 1.11

Find the equivalent mass of the system shown in Fig. 1.38, where the rigid link 1 is attached to the pulley and rotates with it.

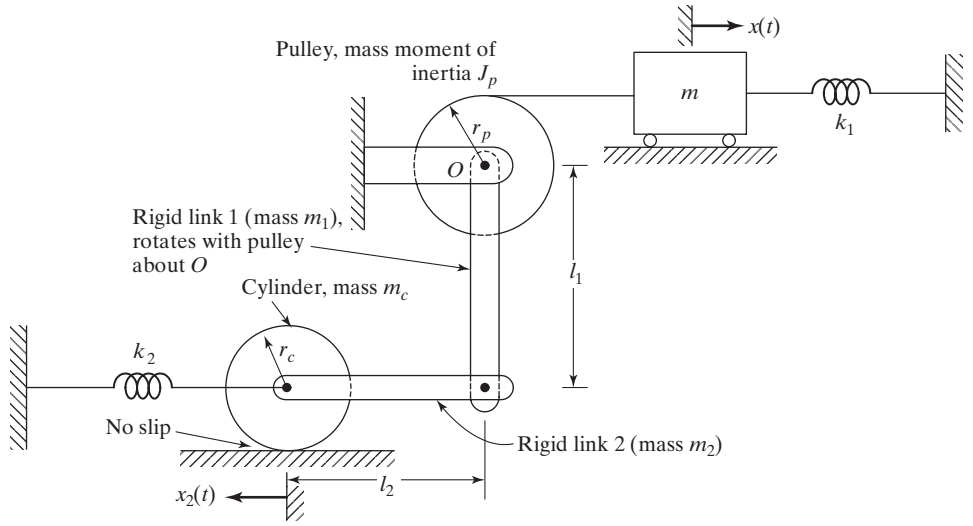

FIGURE 1.38 System considered for finding equivalent mass.

Solution: Assuming small displacements, the equivalent mass (m_{eq}) can be determined using the equivalence of the kinetic energies of the two systems. When the mass m is displaced by a distance x , the pulley and the rigid link 1 rotate by an angle $\theta_p = \theta_1 = x/r_p$. This causes the rigid link 2 and the cylinder to be displaced by a distance $x_2 = \theta_p l_1 = x l_1/r_p$. Since the cylinder rolls without slippage, it rotates by an angle $\theta_c = x_2/r_c = x l_1/r_p r_c$. The kinetic energy of the system (T) can be expressed (for small displacements) as:

$$T = \frac{1}{2} m \dot{x}^2 + \frac{1}{2} J_p \dot{\theta}_p^2 + \frac{1}{2} J_1 \dot{\theta}_1^2 + \frac{1}{2} m_2 \dot{x}_2^2 + \frac{1}{2} J_c \dot{\theta}_c^2 + \frac{1}{2} m_c \dot{x}_2^2 \quad (\text{E.1})$$

where J_p , J_1 , and J_c denote the mass moments of inertia of the pulley, link 1 (about O), and cylinder, respectively, $\dot{\theta}_p$, $\dot{\theta}_1$, and $\dot{\theta}_c$ indicate the angular velocities of the pulley, link 1 (about O), and cylinder, respectively, and \dot{x} and \dot{x}_2 represent the linear velocities of the mass m and link 2, respectively. Noting that $J_c = m_c r_c^2/2$ and $J_1 = m_1 l_1^2/3$, Eq. (E.1) can be rewritten as

$$T = \frac{1}{2} m \dot{x}^2 + \frac{1}{2} J_p \left(\frac{\dot{x}}{r_p} \right)^2 + \frac{1}{2} \left(\frac{m_1 l_1^2}{3} \right) \left(\frac{\dot{x}}{r_p} \right)^2 + \frac{1}{2} m_2 \left(\frac{\dot{x} l_1}{r_p} \right)^2 + \frac{1}{2} \left(\frac{m_c r_c^2}{2} \right) \left(\frac{\dot{x} l_1}{r_p r_c} \right)^2 + \frac{1}{2} m_c \left(\frac{\dot{x} l_1}{r_p} \right)^2 \quad (\text{E.2})$$

By equating Eq. (E.2) to the kinetic energy of the equivalent system

$$T = \frac{1}{2} m_{\text{eq}} \dot{x}^2 \quad (\text{E.3})$$

we obtain the equivalent mass of the system as

$$m_{eq} = m + \frac{J_p}{r_p^2} + \frac{1}{3} \frac{m_1 l_1^2}{r_p^2} + \frac{m_2 l_1^2}{r_p^2} + \frac{1}{2} \frac{m_c l_1^2}{r_p^2} + m_c \frac{l_1^2}{r_p^2} \quad (\text{E.4})$$

■

EXAMPLE 1.12 Cam-Follower Mechanism

A cam-follower mechanism (Fig. 1.39) is used to convert the rotary motion of a shaft into the oscillating or reciprocating motion of a valve. The follower system consists of a pushrod of mass m_p , a rocker arm of mass m_r , and mass moment of inertia J_r about its C.G., a valve of mass m_v , and a valve spring of negligible mass [1.28–1.30]. Find the equivalent mass (m_{eq}) of this cam-follower system by assuming the location of m_{eq} as (i) point A and (ii) point C.

Solution: The equivalent mass of the cam-follower system can be determined using the equivalence of the kinetic energies of the two systems. Due to a vertical displacement x of the pushrod, the rocker arm rotates by an angle $\theta_r = x/l_1$ about the pivot point, the valve moves downward by $x_v = \theta_r l_2 = x l_2 / l_1$, and the C.G. of the rocker arm moves downward by $x_r = \theta_r l_3 = x l_3 / l_1$. The kinetic energy of the system (T) can be expressed as²

$$T = \frac{1}{2} m_p \dot{x}_p^2 + \frac{1}{2} m_v \dot{x}_v^2 + \frac{1}{2} J_r \dot{\theta}_r^2 + \frac{1}{2} m_r \dot{x}_r^2 \quad (\text{E.1})$$

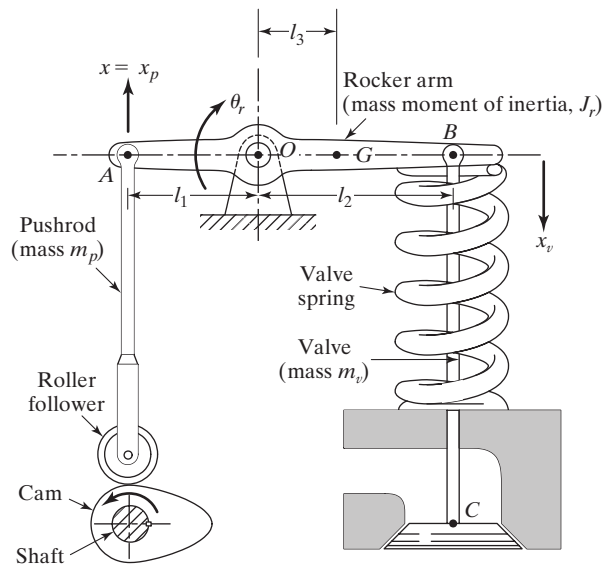

FIGURE 1.39 Cam-follower system.

²If the valve spring has a mass m_s , then its equivalent mass will be $\frac{1}{3} m_s$ (see Example 2.8). Thus the kinetic energy of the valve spring will be $\frac{1}{2} (\frac{1}{3} m_s) \dot{x}_v^2$.

where \dot{x}_p , \dot{x}_r , and \dot{x}_v are the linear velocities of the pushrod, C.G. of the rocker arm, and the valve, respectively, and $\dot{\theta}_r$ is the angular velocity of the rocker arm.

(i) If m_{eq} denotes the equivalent mass placed at point A, with $\dot{x}_{\text{eq}} = \dot{x}$, the kinetic energy of the equivalent mass system T_{eq} is given by

$$T_{\text{eq}} = \frac{1}{2} m_{\text{eq}} \dot{x}_{\text{eq}}^2 \quad (\text{E.2})$$

By equating T and T_{eq} , and noting that

$$\dot{x}_p = \dot{x}, \quad \dot{x}_v = \frac{\dot{x}l_2}{l_1}, \quad \dot{x}_r = \frac{\dot{x}l_3}{l_1}, \quad \text{and} \quad \dot{\theta}_r = \frac{\dot{x}}{l_1}$$

we obtain

$$m_{\text{eq}} = m_p + \frac{J_r}{l_1^2} + m_v \frac{l_2^2}{l_1^2} + m_r \frac{l_3^2}{l_1^2} \quad (\text{E.3})$$

(ii) Similarly, if the equivalent mass is located at point C, $\dot{x}_{\text{eq}} = \dot{x}_v$ and

$$T_{\text{eq}} = \frac{1}{2} m_{\text{eq}} \dot{x}_{\text{eq}}^2 = \frac{1}{2} m_{\text{eq}} \dot{x}_v^2 \quad (\text{E.4})$$

Equating (E.4) and (E.1) gives

$$m_{\text{eq}} = m_v + \frac{J_r}{l_2^2} + m_p \left(\frac{l_1}{l_2} \right)^2 + m_r \left(\frac{l_3}{l_2} \right)^2 \quad (\text{E.5})$$

■

1.9 Damping Elements

In many practical systems, the vibrational energy is gradually converted to heat or sound. Due to the reduction in the energy, the response, such as the displacement of the system, gradually decreases. The mechanism by which the vibrational energy is gradually converted into heat or sound is known as *damping*. Although the amount of energy converted into heat or sound is relatively small, the consideration of damping becomes important for an accurate prediction of the vibration response of a system. A damper is assumed to have neither mass nor elasticity, and damping force exists only if there is relative velocity between the two ends of the damper. It is difficult to determine the causes of damping in practical systems. Hence damping is modeled as one or more of the following types.

Viscous Damping. Viscous damping is the most commonly used damping mechanism in vibration analysis. When mechanical systems vibrate in a fluid medium such as air, gas, water, or oil, the resistance offered by the fluid to the moving body causes energy to be dissipated. In this case, the amount of dissipated energy depends on many factors, such as the size and shape of the vibrating body, the viscosity of the fluid, the frequency of vibration, and the velocity of the vibrating body. In viscous damping, the damping force is proportional to the velocity of the vibrating body. Typical examples of viscous damping

include (1) fluid film between sliding surfaces, (2) fluid flow around a piston in a cylinder, (3) fluid flow through an orifice, and (4) fluid film around a journal in a bearing.

Coulomb or Dry-Friction Damping. Here the damping force is constant in magnitude but opposite in direction to that of the motion of the vibrating body. It is caused by friction between rubbing surfaces that either are dry or have insufficient lubrication.

Material or Solid or Hysteretic Damping. When a material is deformed, energy is absorbed and dissipated by the material [1.31]. The effect is due to friction between the internal planes, which slip or slide as the deformations take place. When a body having material damping is subjected to vibration, the stress-strain diagram shows a hysteresis loop as indicated in Fig. 1.40(a). The area of this loop denotes the energy lost per unit volume of the body per cycle due to damping.³

1.9.1 Construction of Viscous Dampers

Viscous dampers can be constructed in several ways. For instance, when a plate moves relative to another parallel plate with a viscous fluid in between the plates, a viscous damper can be obtained. The following examples illustrate the various methods of constructing viscous dampers used in different applications.

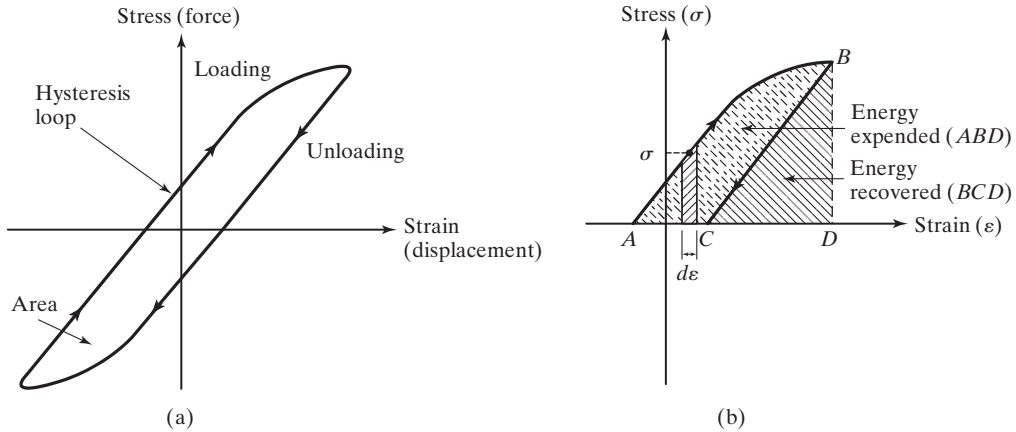

FIGURE 1.40 Hysteresis loop for elastic materials.

³When the load applied to an elastic body is increased, the stress (σ) and the strain (ϵ) in the body also increase. The area under the σ - ϵ curve, given by

$$u = \int \sigma d\epsilon$$

denotes the energy expended (work done) per unit volume of the body. When the load on the body is decreased, energy will be recovered. When the unloading path is different from the loading path, the area ABC in Fig. 1.40(b)—the area of the hysteresis loop in Fig. 1.40(a)—denotes the energy lost per unit volume of the body.

EXAMPLE 1.13**Damping Constant of Parallel Plates Separated by Viscous Fluid**

Consider two parallel plates separated by a distance h , with a fluid of viscosity μ between the plates. Derive an expression for the damping constant when one plate moves with a velocity v relative to the other as shown in Fig. 1.41.

Solution: Let one plate be fixed and let the other plate be moved with a velocity v in its own plane. The fluid layers in contact with the moving plate move with a velocity v , while those in contact with the fixed plate do not move. The velocities of intermediate fluid layers are assumed to vary linearly between 0 and v , as shown in Fig. 1.41. According to Newton's law of viscous flow, the shear stress (τ) developed in the fluid layer at a distance y from the fixed plate is given by

$$\tau = \mu \frac{du}{dy} \quad (\text{E.1})$$

where $du/dy = v/h$ is the velocity gradient. The shear or resisting force (F) developed at the bottom surface of the moving plate is

$$F = \tau A = \frac{\mu A v}{h} \quad (\text{E.2})$$

where A is the surface area of the moving plate. By expressing F as

$$F = c v \quad (\text{E.3})$$

the damping constant c can be found as

$$c = \frac{\mu A}{h} \quad (\text{E.4})$$

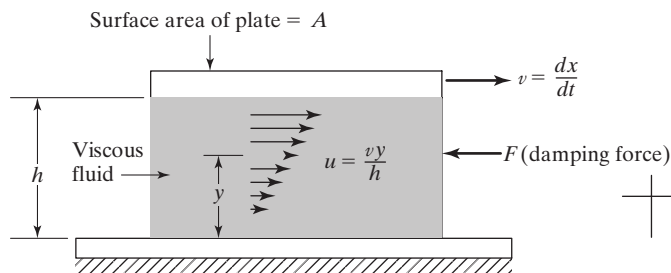

FIGURE 1.41 Parallel plates with a viscous fluid in between. ■

EXAMPLE 1.14**Clearance in a Bearing**

A bearing, which can be approximated as two flat plates separated by a thin film of lubricant (Fig. 1.42), is found to offer a resistance of 400 N when SAE 30 oil is used as the lubricant and the relative velocity between the plates is 10 m/s. If the area of the plates (A) is 0.1 m², determine the clearance between the plates. Assume the absolute viscosity of SAE 30 oil as 50 μreyn or 0.3445 Pa-s.

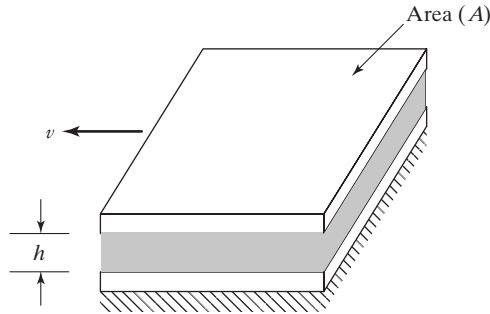

FIGURE 1.42 Flat plates separated by thin film of lubricant.

Solution: Since the resisting force (F) can be expressed as $F = cv$, where c is the damping constant and v is the velocity, we have

$$c = \frac{F}{v} = \frac{400}{10} = 40 \text{ N-s/m} \quad (\text{E.1})$$

By modeling the bearing as a flat-plate-type damper, the damping constant is given by Eq. (E.4) of Example 1.13:

$$c = \frac{\mu A}{h} \quad (\text{E.2})$$

Using the known data, Eq. (E.2) gives

$$c = 40 = \frac{(0.3445)(0.1)}{h} \quad \text{or} \quad h = 0.86125 \text{ mm} \quad (\text{E.3})$$

■

EXAMPLE 1.15 Damping Constant of a Journal Bearing

A journal bearing is used to provide lateral support to a rotating shaft as shown in Fig. 1.43. If the radius of the shaft is R , angular velocity of the shaft is ω , radial clearance between the shaft and the bearing is d , viscosity of the fluid (lubricant) is μ , and the length of the bearing is l , derive an expression for the rotational damping constant of the journal bearing. Assume that the leakage of the fluid is negligible.

Solution: The damping constant of the journal bearing can be determined using the equation for the shear stress in viscous fluid. The fluid in contact with the rotating shaft will have a linear velocity (in tangential direction) of $v = R\omega$, while the fluid in contact with the stationary bearing will have zero velocity. Assuming a linear variation for the velocity of the fluid in the radial direction, we have

$$v(r) = \frac{vr}{d} = \frac{rR\omega}{d} \quad (\text{E.1})$$

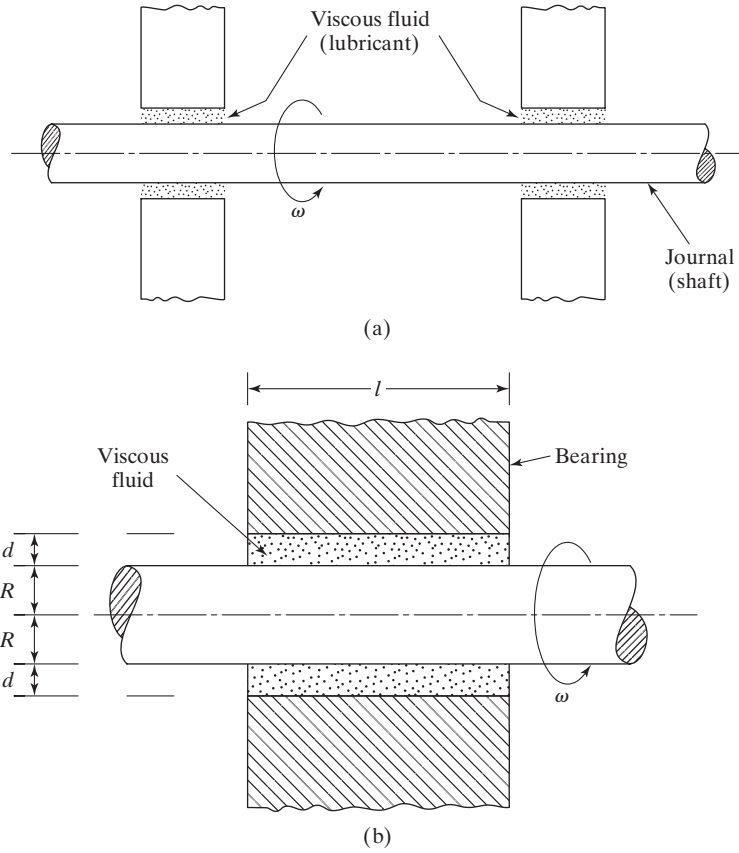

FIGURE 1.43 A journal bearing.

The shearing stress (τ) in the lubricant is given by the product of the radial velocity gradient and the viscosity of the lubricant:

$$\tau = \mu \frac{dv}{dr} = \frac{\mu R \omega}{d} \quad (\text{E.2})$$

The force required to shear the fluid film is equal to stress times the area. The torque on the shaft (T) is equal to the force times the lever arm, so that

$$T = (\tau A) R \quad (\text{E.3})$$

where $A = 2\pi Rl$ is the surface area of the shaft exposed to the lubricant. Thus Eq. (E.3) can be rewritten as

$$T = \left(\frac{\mu R \omega}{d} \right) (2\pi Rl) R = \frac{2\pi \mu R^3 l \omega}{d} \quad (\text{E.4})$$

From the definition of the rotational damping constant of the bearing (c_t):

$$c_t = \frac{T}{\omega} \tag{E.5}$$

we obtain the desired expression for the rotational damping constant as

$$c_t = \frac{2\pi\mu R^3 l}{d} \tag{E.6}$$

Note: Equation (E.4) is called Petroff's law and was published originally in 1883. This equation is widely used in the design of journal bearings [1.43].

■

EXAMPLE 1.16 Piston-Cylinder Dashpot

Develop an expression for the damping constant of the dashpot shown in Fig. 1.44(a).

Solution: The damping constant of the dashpot can be determined using the shear-stress equation for viscous fluid flow and the rate-of-fluid-flow equation. As shown in Fig. 1.44(a), the dashpot consists of a piston of diameter D and length l , moving with velocity v_0 in a cylinder filled with a liquid of viscosity μ [1.24, 1.32]. Let the clearance between the piston and the cylinder wall be d . At a distance y from the moving surface, let the velocity and shear stress be v and τ , and at a distance $(y + dy)$ let the velocity and shear stress be $(v - dv)$ and $(\tau + d\tau)$, respectively (see Fig. 1.44(b)). The negative sign for dv shows that the velocity decreases as we move toward the cylinder wall. The viscous force on this annular ring is equal to

$$F = \pi D l d\tau = \pi D l \frac{d\tau}{dy} dy \tag{E.1}$$

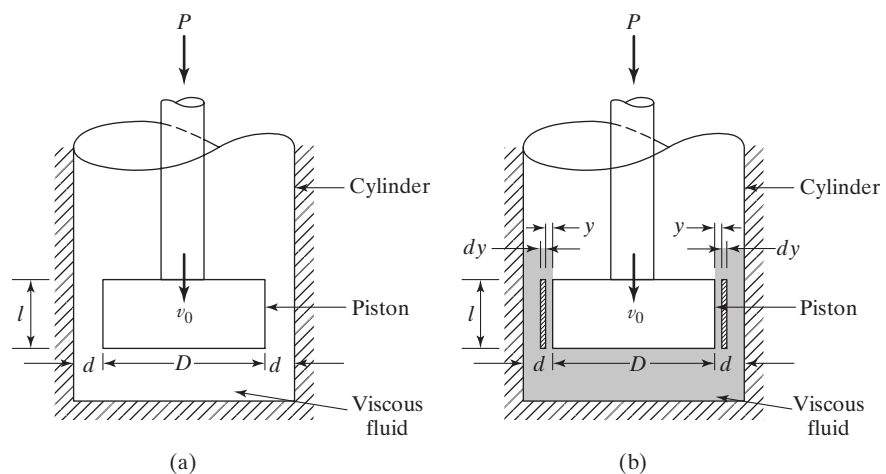

FIGURE 1.44 A dashpot.

But the shear stress is given by

$$\tau = -\mu \frac{dv}{dy} \quad (\text{E.2})$$

where the negative sign is consistent with a decreasing velocity gradient [1.33]. Using Eq. (E.2) in Eq. (E.1), we obtain

$$F = -\pi D l dy \mu \frac{d^2v}{dy^2} \quad (\text{E.3})$$

The force on the piston will cause a pressure difference on the ends of the element, given by

$$p = \frac{P}{\left(\frac{\pi D^2}{4}\right)} = \frac{4P}{\pi D^2} \quad (\text{E.4})$$

Thus the pressure force on the end of the element is

$$p(\pi D dy) = \frac{4P}{D} dy \quad (\text{E.5})$$

where $(\pi D dy)$ denotes the annular area between y and $(y + dy)$. If we assume uniform mean velocity in the direction of motion of the fluid, the forces given in Eqs. (E.3) and (E.5) must be equal. Thus we get

$$\frac{4P}{D} dy = -\pi D l dy \mu \frac{d^2v}{dy^2}$$

or

$$\frac{d^2v}{dy^2} = -\frac{4P}{\pi D^2 l \mu} \quad (\text{E.6})$$

Integrating this equation twice and using the boundary conditions $v = -v_0$ at $y = 0$ and $v = 0$ at $y = d$, we obtain

$$v = \frac{2P}{\pi D^2 l \mu} (yd - y^2) - v_0 \left(1 - \frac{y}{d}\right) \quad (\text{E.7})$$

The rate of flow through the clearance space can be obtained by integrating the rate of flow through an element between the limits $y = 0$ and $y = d$:

$$Q = \int_0^d v \pi D dy = \pi D \left[\frac{2Pd^3}{6\pi D^2 l \mu} - \frac{1}{2} v_0 d \right] \quad (\text{E.8})$$

The volume of the liquid flowing through the clearance space per second must be equal to the volume per second displaced by the piston. Hence the velocity of the piston will be equal to this rate of flow divided by the piston area. This gives

$$v_0 = \frac{Q}{\left(\frac{\pi D^2}{4}\right)} \quad (\text{E.9})$$

Equations (E.9) and (E.8) lead to

$$P = \left[\frac{3\pi D^3 l \left(1 + \frac{2d}{D}\right)}{4d^3} \right] \mu v_0 \quad (\text{E.10})$$

By writing the force as $P = cv_0$, the damping constant c can be found as

$$c = \mu \left[\frac{3\pi D^3 l \left(1 + \frac{2d}{D}\right)}{4d^3} \right] \quad (\text{E.11})$$

■

1.9.2 Linearization of a Nonlinear Damper

If the force (F)-velocity (v) relationship of a damper is nonlinear:

$$F = F(v) \quad (1.26)$$

a linearization process can be used about the operating velocity (v^*), as in the case of a nonlinear spring. The linearization process gives the equivalent damping constant as

$$c = \left. \frac{dF}{dv} \right|_{v^*} \quad (1.27)$$

1.9.3 Combination of Dampers

In some dynamic systems, multiple dampers are used. In such cases, all the dampers are replaced by a single equivalent damper. When dampers appear in combination, we can use procedures similar to those used in finding the equivalent spring constant of multiple springs to find a single equivalent damper. For example, when two translational dampers, with damping constants c_1 and c_2 , appear in combination, the equivalent damping constant (c_{eq}) can be found as (see Problem 1.55):

$$\text{Parallel dampers: } c_{\text{eq}} = c_1 + c_2 \quad (1.28)$$

$$\text{Series dampers: } \frac{1}{c_{\text{eq}}} = \frac{1}{c_1} + \frac{1}{c_2} \quad (1.29)$$

EXAMPLE 1.17 Equivalent Spring and Damping Constants of a Machine Tool Support

A precision milling machine is supported on four shock mounts, as shown in Fig. 1.45(a). The elasticity and damping of each shock mount can be modeled as a spring and a viscous damper, as shown in Fig. 1.45(b). Find the equivalent spring constant, k_{eq} , and the equivalent damping constant, c_{eq} , of the machine tool support in terms of the spring constants (k_i) and damping constants (c_i) of the mounts.

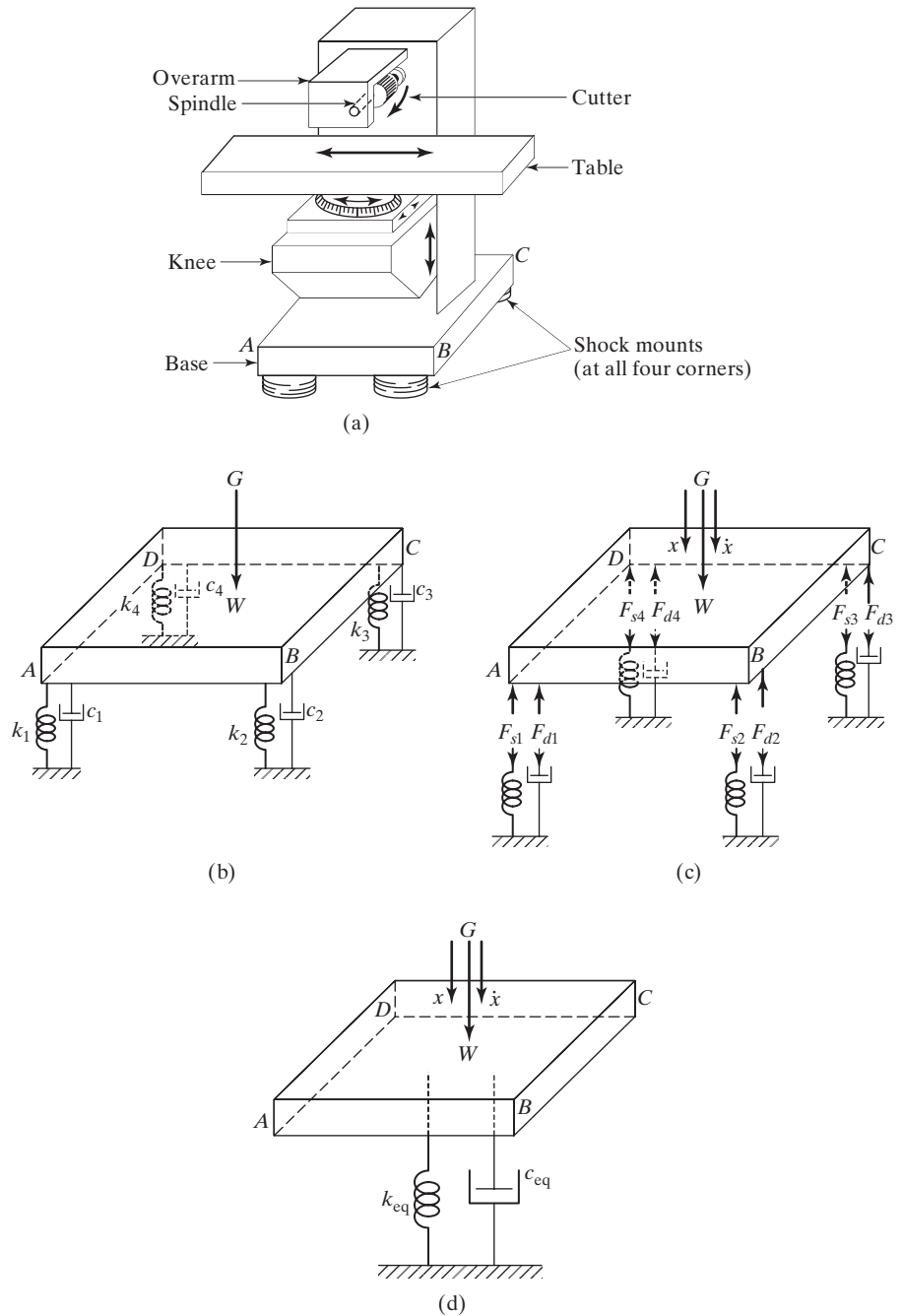

FIGURE 1.45 Horizontal milling machine.

Solution: The free-body diagrams of the four springs and four dampers are shown in Fig. 1.45(c). Assuming that the center of mass, G , is located symmetrically with respect to the four springs and dampers, we notice that all the springs will be subjected to the same displacement, x , and all the dampers will be subject to the same relative velocity \dot{x} , where x and \dot{x} denote the displacement and velocity, respectively, of the center of mass, G . Hence the forces acting on the springs (F_{si}) and the dampers (F_{di}) can be expressed as

$$\begin{aligned} F_{si} &= k_i x; & i &= 1, 2, 3, 4 \\ F_{di} &= c_i \dot{x}; & i &= 1, 2, 3, 4 \end{aligned} \quad (\text{E.1})$$

Let the total forces acting on all the springs and all the dampers be F_s and F_d , respectively (see Fig. 1.45(d)). The force equilibrium equations can thus be expressed as

$$\begin{aligned} F_s &= F_{s1} + F_{s2} + F_{s3} + F_{s4} \\ F_d &= F_{d1} + F_{d2} + F_{d3} + F_{d4} \end{aligned} \quad (\text{E.2})$$

where $F_s + F_d = W$, with W denoting the total vertical force (including the inertia force) acting on the milling machine. From Fig. 1.45(d), we have

$$\begin{aligned} F_s &= k_{\text{eq}} x \\ F_d &= c_{\text{eq}} \dot{x} \end{aligned} \quad (\text{E.3})$$

Equation (E.2), along with Eqs. (E.1) and (E.3), yields

$$\begin{aligned} k_{\text{eq}} &= k_1 + k_2 + k_3 + k_4 = 4k \\ c_{\text{eq}} &= c_1 + c_2 + c_3 + c_4 = 4c \end{aligned} \quad (\text{E.4})$$

when $k_i = k$ and $c_i = c$ for $i = 1, 2, 3, 4$.

Note: If the center of mass, G , is not located symmetrically with respect to the four springs and dampers, the i th spring experiences a displacement of x_i and the i th damper experiences a velocity of \dot{x}_i , where x_i and \dot{x}_i can be related to the displacement x and velocity \dot{x} of the center of mass of the milling machine, G . In such a case, Eqs. (E.1) and (E.4) need to be modified suitably. ■

1.10 Harmonic Motion

Oscillatory motion may repeat itself regularly, as in the case of a simple pendulum, or it may display considerable irregularity, as in the case of ground motion during an earthquake. If the motion is repeated after equal intervals of time, it is called *periodic motion*. The simplest type of periodic motion is *harmonic motion*. The motion imparted to the mass m due to the Scotch yoke mechanism shown in Fig. 1.46 is an example of simple harmonic motion [1.24, 1.34, 1.35]. In this system, a crank of radius A rotates about the point O . The other end of the crank, P , slides in a slotted rod, which reciprocates in the vertical guide R . When the crank rotates at an angular velocity ω , the end point S of the slotted link and

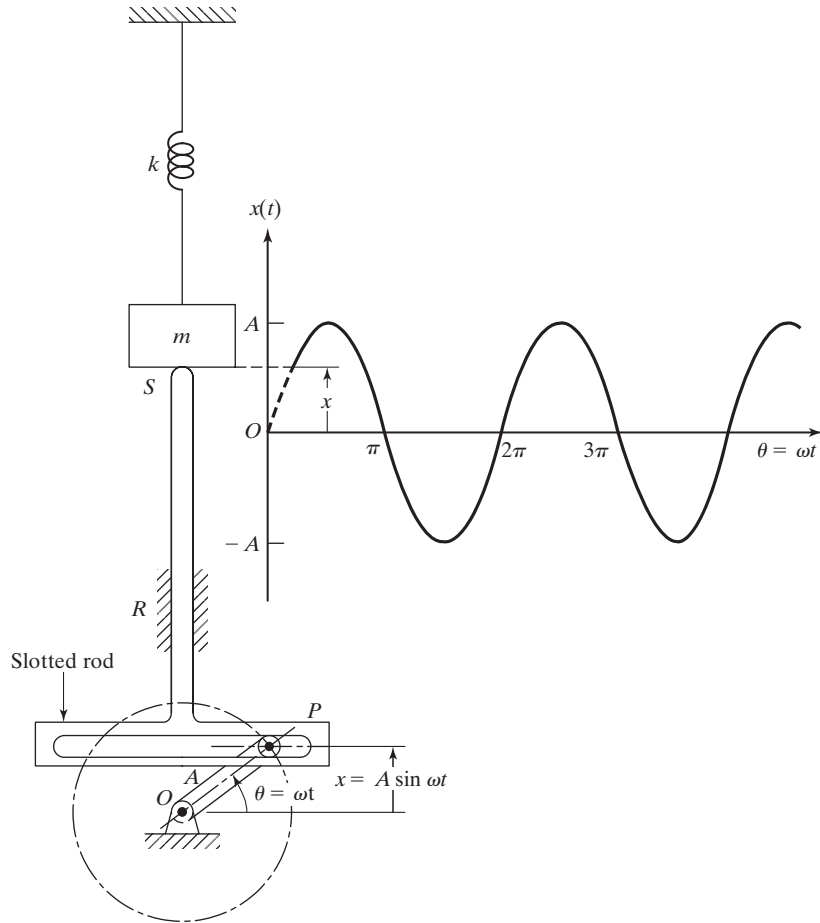

FIGURE 1.46 Scotch yoke mechanism.

hence the mass m of the spring-mass system are displaced from their middle positions by an amount x (in time t) given by

$$x = A \sin \theta = A \sin \omega t \quad (1.30)$$

This motion is shown by the sinusoidal curve in Fig. 1.46. The velocity of the mass m at time t is given by

$$\frac{dx}{dt} = \omega A \cos \omega t \quad (1.31)$$

and the acceleration by

$$\frac{d^2x}{dt^2} = -\omega^2 A \sin \omega t = -\omega^2 x \quad (1.32)$$

It can be seen that the acceleration is directly proportional to the displacement. Such a vibration, with the acceleration proportional to the displacement and directed toward the mean position, is known as *simple harmonic motion*. The motion given by $x = A \cos \omega t$ is another example of a simple harmonic motion. Figure 1.46 clearly shows the similarity between cyclic (harmonic) motion and sinusoidal motion.

1.10.1 Vectorial Representation of Harmonic Motion

Harmonic motion can be represented conveniently by means of a vector \vec{OP} of magnitude A rotating at a constant angular velocity ω . In Fig. 1.47, the projection of the tip of the vector $\vec{X} = \vec{OP}$ on the vertical axis is given by

$$y = A \sin \omega t \tag{1.33}$$

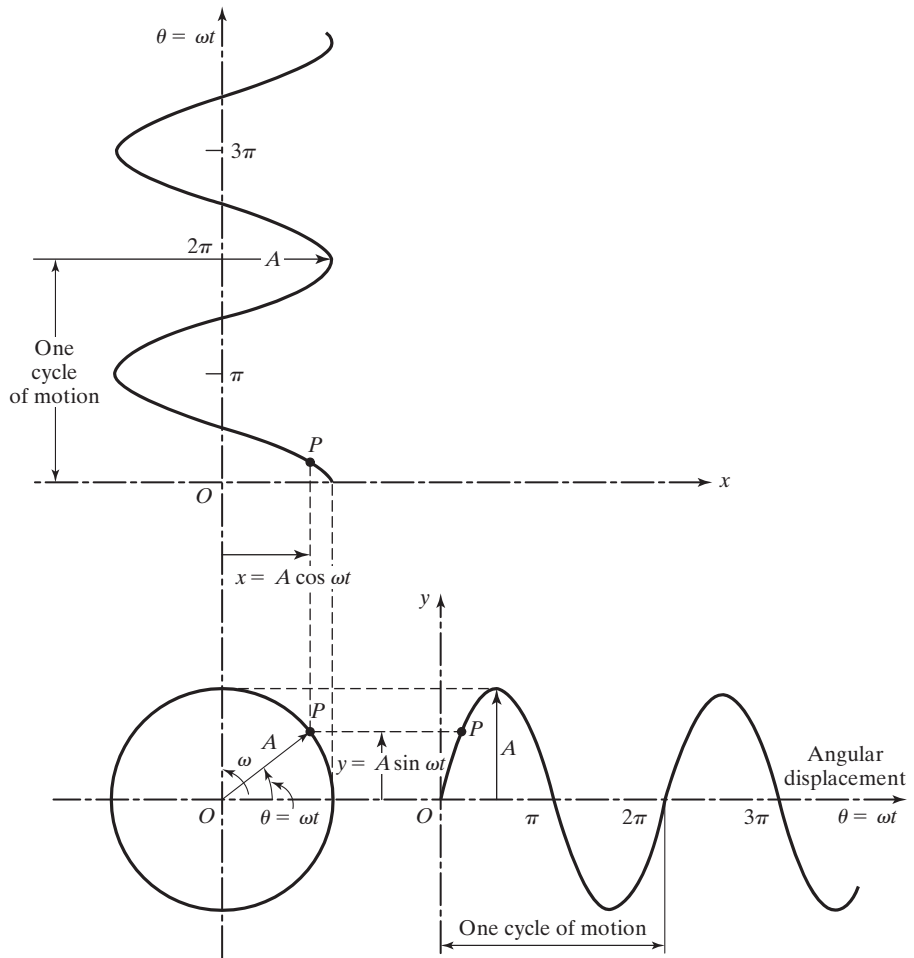

FIGURE 1.47 Harmonic motion as the projection of the end of a rotating vector.

and its projection on the horizontal axis by

$$x = A \cos \omega t \quad (1.34)$$

1.10.2 Complex- Number Representation of Harmonic Motion

As seen above, the vectorial method of representing harmonic motion requires the description of both the horizontal and vertical components. It is more convenient to represent harmonic motion using a complex-number representation. Any vector \vec{X} in the xy -plane can be represented as a complex number:

$$\vec{X} = a + ib \quad (1.35)$$

where $i = \sqrt{-1}$ and a and b denote the x and y components of \vec{X} , respectively (see Fig. 1.48). Components a and b are also called the *real* and *imaginary* parts of the vector \vec{X} . If A denotes the modulus or absolute value of the vector \vec{X} , and θ represents the argument or the angle between the vector and the x -axis, then \vec{X} can also be expressed as

$$\vec{X} = A \cos \theta + iA \sin \theta \quad (1.36)$$

with

$$A = (a^2 + b^2)^{1/2} \quad (1.37)$$

and

$$\theta = \tan^{-1} \frac{b}{a} \quad (1.38)$$

Noting that $i^2 = -1$, $i^3 = -i$, $i^4 = 1$, \dots , $\cos \theta$ and $i \sin \theta$ can be expanded in a series as

$$\cos \theta = 1 - \frac{\theta^2}{2!} + \frac{\theta^4}{4!} - \dots = 1 + \frac{(i\theta)^2}{2!} + \frac{(i\theta)^4}{4!} + \dots \quad (1.39)$$

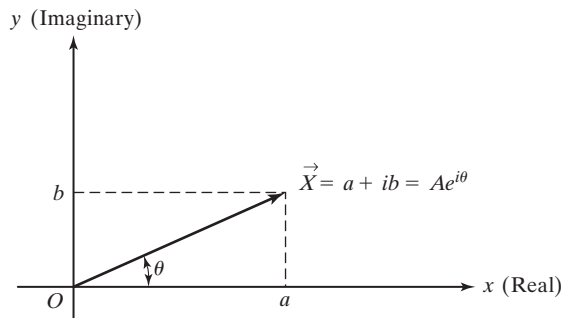

FIGURE 1.48 Representation of a complex number.

$$i \sin \theta = i \left[\theta - \frac{\theta^3}{3!} + \frac{\theta^5}{5!} - \dots \right] = i\theta + \frac{(i\theta)^3}{3!} + \frac{(i\theta)^5}{5!} + \dots \quad (1.40)$$

Equations (1.39) and (1.40) yield

$$(\cos \theta + i \sin \theta) = 1 + i\theta + \frac{(i\theta)^2}{2!} + \frac{(i\theta)^3}{3!} + \dots = e^{i\theta} \quad (1.41)$$

and

$$(\cos \theta - i \sin \theta) = 1 - i\theta + \frac{(i\theta)^2}{2!} - \frac{(i\theta)^3}{3!} + \dots = e^{-i\theta} \quad (1.42)$$

Thus Eq. (1.36) can be expressed as

$$\vec{X} = A(\cos \theta + i \sin \theta) = Ae^{i\theta} \quad (1.43)$$

1.10.3 Complex Algebra

Complex numbers are often represented without using a vector notation as

$$z = a + ib \quad (1.44)$$

where a and b denote the real and imaginary parts of z . The addition, subtraction, multiplication, and division of complex numbers can be achieved by using the usual rules of algebra. Let

$$z_1 = a_1 + ib_1 = A_1 e^{i\theta_1} \quad (1.45)$$

$$z_2 = a_2 + ib_2 = A_2 e^{i\theta_2} \quad (1.46)$$

where

$$A_j = \sqrt{a_j^2 + b_j^2}; \quad j = 1, 2 \quad (1.47)$$

and

$$\theta_j = \tan^{-1} \left(\frac{b_j}{a_j} \right); \quad j = 1, 2 \quad (1.48)$$

The sum and difference of z_1 and z_2 can be found as

$$\begin{aligned} z_1 + z_2 &= A_1 e^{i\theta_1} + A_2 e^{i\theta_2} = (a_1 + ib_1) + (a_2 + ib_2) \\ &= (a_1 + a_2) + i(b_1 + b_2) \end{aligned} \quad (1.49)$$

$$\begin{aligned} z_1 - z_2 &= A_1 e^{i\theta_1} - A_2 e^{i\theta_2} = (a_1 + ib_1) - (a_2 + ib_2) \\ &= (a_1 - a_2) + i(b_1 - b_2) \end{aligned} \quad (1.50)$$

1.10.4 Operations on Harmonic Functions

Using complex-number representation, the rotating vector \vec{X} of Fig. 1.47 can be written as

$$\vec{X} = Ae^{i\omega t} \quad (1.51)$$

where ω denotes the circular frequency (rad/sec) of rotation of the vector \vec{X} in counter-clockwise direction. The differentiation of the harmonic motion given by Eq. (1.51) with respect to time gives

$$\frac{d\vec{X}}{dt} = \frac{d}{dt}(Ae^{i\omega t}) = i\omega Ae^{i\omega t} = i\omega\vec{X} \quad (1.52)$$

$$\frac{d^2\vec{X}}{dt^2} = \frac{d}{dt}(i\omega Ae^{i\omega t}) = -\omega^2 Ae^{i\omega t} = -\omega^2\vec{X} \quad (1.53)$$

Thus the displacement, velocity, and acceleration can be expressed as⁴

$$\text{displacement} = \text{Re}[Ae^{i\omega t}] = A \cos \omega t \quad (1.54)$$

$$\begin{aligned} \text{velocity} &= \text{Re}[i\omega Ae^{i\omega t}] = -\omega A \sin \omega t \\ &= \omega A \cos(\omega t + 90^\circ) \end{aligned} \quad (1.55)$$

$$\begin{aligned} \text{acceleration} &= \text{Re}[-\omega^2 Ae^{i\omega t}] = -\omega^2 A \cos \omega t \\ &= \omega^2 A \cos(\omega t + 180^\circ) \end{aligned} \quad (1.56)$$

where Re denotes the real part. These quantities are shown as rotating vectors in Fig. 1.49. It can be seen that the acceleration vector leads the velocity vector by 90° , and the latter leads the displacement vector by 90° .

Harmonic functions can be added vectorially, as shown in Fig. 1.50. If $\text{Re}(\vec{X}_1) = A_1 \cos \omega t$ and $\text{Re}(\vec{X}_2) = A_2 \cos(\omega t + \theta)$, then the magnitude of the resultant vector \vec{X} is given by

$$A = \sqrt{(A_1 + A_2 \cos \theta)^2 + (A_2 \sin \theta)^2} \quad (1.57)$$

and the angle α by

$$\alpha = \tan^{-1} \left(\frac{A_2 \sin \theta}{A_1 + A_2 \cos \theta} \right) \quad (1.58)$$

⁴If the harmonic displacement is originally given as $x(t) = A \sin \omega t$, then we have

$$\begin{aligned} \text{displacement} &= \text{Im}[Ae^{i\omega t}] = A \sin \omega t \\ \text{velocity} &= \text{Im}[i\omega Ae^{i\omega t}] = \omega A \sin(\omega t + 90^\circ) \\ \text{acceleration} &= \text{Im}[-\omega^2 Ae^{i\omega t}] = \omega^2 A \sin(\omega t + 180^\circ) \end{aligned}$$

where Im denotes the imaginary part.

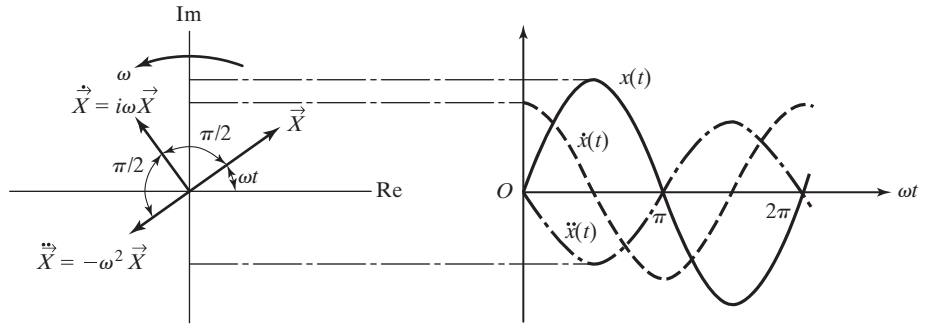

FIGURE 1.49 Displacement, velocity, and accelerations as rotating vectors.

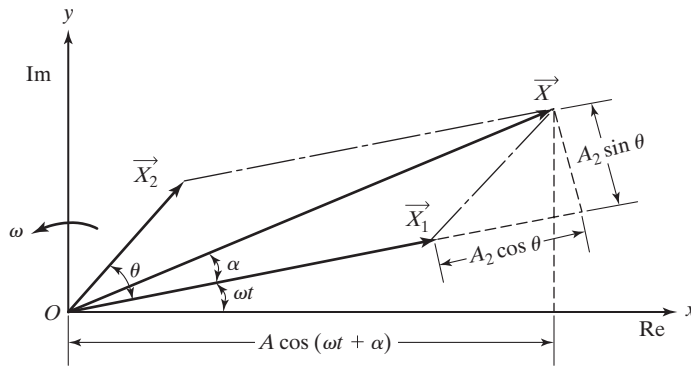

FIGURE 1.50 Vectorial addition of harmonic functions.

Since the original functions are given as real components, the sum $\vec{X}_1 + \vec{X}_2$ is given by $\text{Re}(\vec{X}) = A \cos(\omega t + \alpha)$.

EXAMPLE 1.18 Addition of Harmonic Motions

Find the sum of the two harmonic motions $x_1(t) = 10 \cos \omega t$ and $x_2(t) = 15 \cos(\omega t + 2)$.

Solution: *Method 1: By using trigonometric relations:* Since the circular frequency is the same for both $x_1(t)$ and $x_2(t)$, we express the sum as

$$x(t) = A \cos(\omega t + \alpha) = x_1(t) + x_2(t) \quad (\text{E.1})$$

That is,

$$\begin{aligned} A(\cos \omega t \cos \alpha - \sin \omega t \sin \alpha) &= 10 \cos \omega t + 15 \cos(\omega t + 2) \\ &= 10 \cos \omega t + 15(\cos \omega t \cos 2 - \sin \omega t \sin 2) \end{aligned} \quad (\text{E.2})$$

That is,

$$\cos \omega t (A \cos \alpha) - \sin \omega t (A \sin \alpha) = \cos \omega t (10 + 15 \cos 2) - \sin \omega t (15 \sin 2) \quad (\text{E.3})$$

By equating the corresponding coefficients of $\cos \omega t$ and $\sin \omega t$ on both sides, we obtain

$$A \cos \alpha = 10 + 15 \cos 2$$

$$A \sin \alpha = 15 \sin 2$$

$$\begin{aligned} A &= \sqrt{(10 + 15 \cos 2)^2 + (15 \sin 2)^2} \\ &= 14.1477 \end{aligned} \quad (\text{E.4})$$

and

$$\alpha = \tan^{-1} \left(\frac{15 \sin 2}{10 + 15 \cos 2} \right) = 74.5963^\circ \quad (\text{E.5})$$

Method 2: By using vectors: For an arbitrary value of ωt , the harmonic motions $x_1(t)$ and $x_2(t)$ can be denoted graphically as shown in Fig. 1.51. By adding them vectorially, the resultant vector $x(t)$ can be found to be

$$x(t) = 14.1477 \cos(\omega t + 74.5963^\circ) \quad (\text{E.6})$$

Method 3: By using complex-number representation: The two harmonic motions can be denoted in terms of complex numbers:

$$x_1(t) = \text{Re}[A_1 e^{i\omega t}] \equiv \text{Re}[10 e^{i\omega t}]$$

$$x_2(t) = \text{Re}[A_2 e^{i(\omega t + 2)}] \equiv \text{Re}[15 e^{i(\omega t + 2)}] \quad (\text{E.7})$$

The sum of $x_1(t)$ and $x_2(t)$ can be expressed as

$$x(t) = \text{Re}[A e^{i(\omega t + \alpha)}] \quad (\text{E.8})$$

where A and α can be determined using Eqs. (1.47) and (1.48) as $A = 14.1477$ and $\alpha = 74.5963^\circ$.

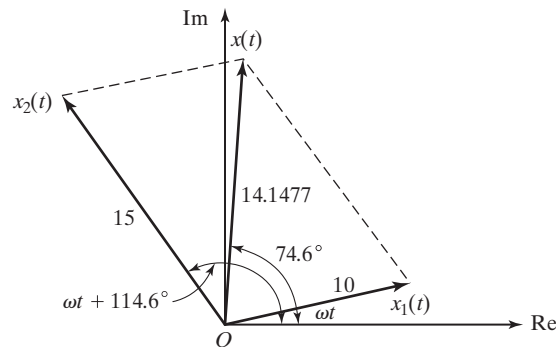

FIGURE 1.51 Addition of harmonic motions. ■

1.10.5 Definitions and Terminology

The following definitions and terminology are useful in dealing with harmonic motion and other periodic functions.

Cycle. The movement of a vibrating body from its undisturbed or equilibrium position to its extreme position in one direction, then to the equilibrium position, then to its extreme position in the other direction, and back to equilibrium position is called a *cycle* of vibration. One revolution (i.e., angular displacement of 2π radians) of the pin P in Fig. 1.46 or one revolution of the vector \overrightarrow{OP} in Fig. 1.47 constitutes a cycle.

Amplitude. The maximum displacement of a vibrating body from its equilibrium position is called the *amplitude* of vibration. In Figs. 1.46 and 1.47 the amplitude of vibration is equal to A .

Period of oscillation. The time taken to complete one cycle of motion is known as the *period of oscillation* or *time period* and is denoted by τ . It is equal to the time required for the vector \overrightarrow{OP} in Fig. 1.47 to rotate through an angle of 2π and hence

$$\tau = \frac{2\pi}{\omega} \quad (1.59)$$

where ω is called the circular frequency.

Frequency of oscillation. The number of cycles per unit time is called the *frequency of oscillation* or simply the *frequency* and is denoted by f . Thus

$$f = \frac{1}{\tau} = \frac{\omega}{2\pi} \quad (1.60)$$

Here ω is called the circular frequency to distinguish it from the linear frequency $f = \omega/2\pi$. The variable ω denotes the angular velocity of the cyclic motion; f is measured in cycles per second (hertz) while ω is measured in radians per second.

Phase angle. Consider two vibratory motions denoted by

$$x_1 = A_1 \sin \omega t \quad (1.61)$$

$$x_2 = A_2 \sin(\omega t + \phi) \quad (1.62)$$

The two harmonic motions given by Eqs. (1.61) and (1.62) are called *synchronous* because they have the same frequency or angular velocity, ω . Two synchronous oscillations need not have the same amplitude, and they need not attain their maximum values at the same time. The motions given by Eqs. (1.61) and (1.62) can be represented graphically as shown in Fig. 1.52. In this figure, the second vector $\overrightarrow{OP_2}$ leads the first one $\overrightarrow{OP_1}$ by an angle ϕ , known as the *phase angle*. This means that the maximum of the second vector would occur ϕ radians earlier than that of the first vector. Note that instead of maxima, any other corresponding points can be taken for finding the phase angle. In Eqs. (1.61) and (1.62) or in Fig. 1.52 the two vectors are said to have a *phase difference* of ϕ .

Natural frequency. If a system, after an initial disturbance, is left to vibrate on its own, the frequency with which it oscillates without external forces is known as its *natural frequency*. As will be seen later, a vibratory system having n degrees of freedom will have, in general, n distinct natural frequencies of vibration.

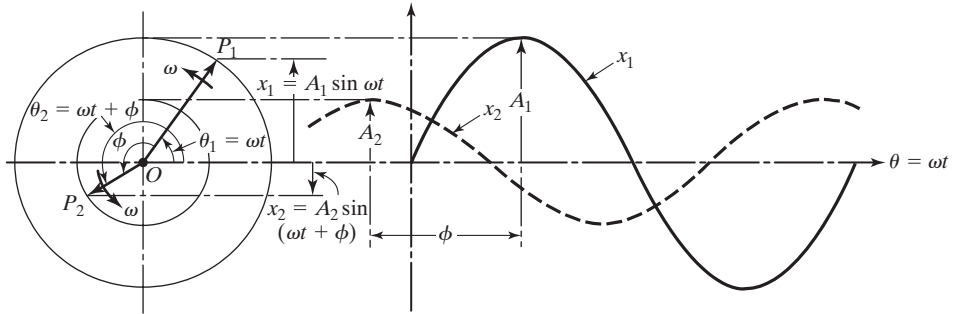

FIGURE 1.52 Phase difference between two vectors.

Beats. When two harmonic motions, with frequencies close to one another, are added, the resulting motion exhibits a phenomenon known as beats. For example, if

$$x_1(t) = X \cos \omega t \quad (1.63)$$

$$x_2(t) = X \cos(\omega + \delta)t \quad (1.64)$$

where δ is a small quantity, the addition of these motions yields

$$x(t) = x_1(t) + x_2(t) = X[\cos \omega t + \cos(\omega + \delta)t] \quad (1.65)$$

Using the relation

$$\cos A + \cos B = 2 \cos\left(\frac{A+B}{2}\right) \cos\left(\frac{A-B}{2}\right) \quad (1.66)$$

Eq. (1.65) can be rewritten as

$$x(t) = 2X \cos \frac{\delta t}{2} \cos\left(\omega + \frac{\delta}{2}\right)t \quad (1.67)$$

This equation is shown graphically in Fig. 1.53. It can be seen that the resulting motion, $x(t)$, represents a cosine wave with frequency $\omega + \delta/2$, which is approximately equal to ω , and with a varying amplitude of $2X \cos \delta t/2$. Whenever the amplitude reaches a maximum, it is called a beat. The frequency (δ) at which the amplitude builds up and dies down between 0 and $2X$ is known as beat frequency. The phenomenon of beats is often observed in machines, structures, and electric power houses. For example, in machines and structures, the beating phenomenon occurs when the forcing frequency is close to the natural frequency of the system (see Section 3.3.2).

Octave. When the maximum value of a range of frequency is twice its minimum value, it is known as an octave band. For example, each of the ranges 75–150 Hz, 150–300 Hz, and 300–600 Hz can be called an octave band. In each case, the maximum and minimum values of frequency, which have a ratio of 2:1, are said to differ by an *octave*.

Decibel. The various quantities encountered in the field of vibration and sound (such as displacement, velocity, acceleration, pressure, and power) are often represented

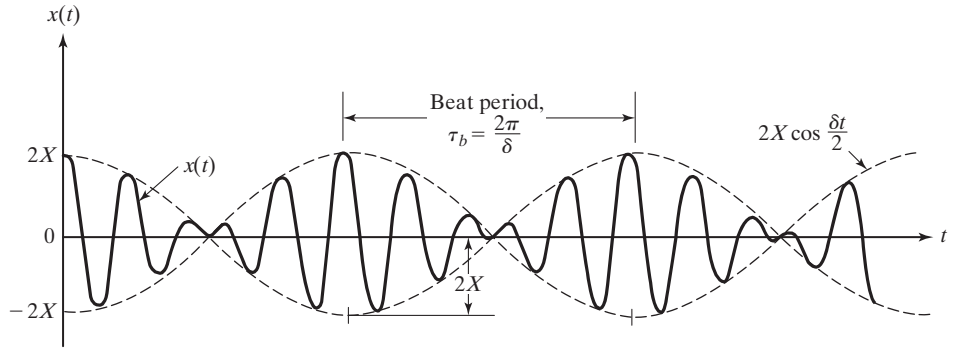

FIGURE 1.53 Phenomenon of beats.

using the notation of *decibel*. A decibel (dB) is originally defined as a ratio of electric powers:

$$\text{dB} = 10 \log\left(\frac{P}{P_0}\right) \tag{1.68}$$

where P_0 is some reference value of power. Since electric power is proportional to the square of the voltage (X), the decibel can also be expressed as

$$\text{dB} = 10 \log\left(\frac{X}{X_0}\right)^2 = 20 \log\left(\frac{X}{X_0}\right) \tag{1.69}$$

where X_0 is a specified reference voltage. In practice, Eq. (1.69) is also used for expressing the ratios of other quantities such as displacements, velocities, accelerations, and pressures. The reference values of X_0 in Eq. (1.69) are usually taken as 2×10^{-5} N/m² for pressure and $1 \mu\text{g} = 9.81 \times 10^{-6}$ m/s² for acceleration.

1.11 Harmonic Analysis⁵

Although harmonic motion is simplest to handle, the motion of many vibratory systems is not harmonic. However, in many cases the vibrations are periodic—for example, the type shown in Fig. 1.54(a). Fortunately, any periodic function of time can be represented by Fourier series as an infinite sum of sine and cosine terms [1.36].

1.11.1 Fourier Series Expansion

If $x(t)$ is a periodic function with period τ , its Fourier series representation is given by

$$\begin{aligned} x(t) &= \frac{a_0}{2} + a_1 \cos \omega t + a_2 \cos 2 \omega t + \dots \\ &\quad + b_1 \sin \omega t + b_2 \sin 2 \omega t + \dots \\ &= \frac{a_0}{2} + \sum_{n=1}^{\infty} (a_n \cos n \omega t + b_n \sin n \omega t) \end{aligned} \tag{1.70}$$

⁵The harmonic analysis forms a basis for Section 4.2.

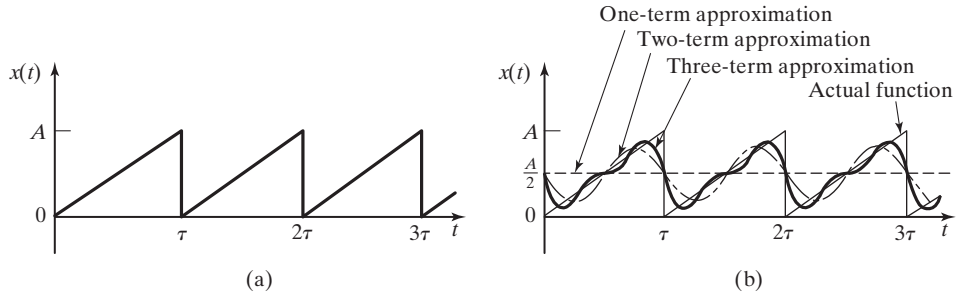

FIGURE 1.54 A periodic function.

where $\omega = 2\pi/\tau$ is the fundamental frequency and $a_0, a_1, a_2, \dots, b_1, b_2, \dots$ are constant coefficients. To determine the coefficients a_n and b_n , we multiply Eq. (1.70) by $\cos n\omega t$ and $\sin n\omega t$, respectively, and integrate over one period $\tau = 2\pi/\omega$ —for example, from 0 to $2\pi/\omega$. Then we notice that all terms except one on the right-hand side of the equation will be zero, and we obtain

$$a_0 = \frac{\omega}{\pi} \int_0^{2\pi/\omega} x(t) dt = \frac{2}{\tau} \int_0^\tau x(t) dt \quad (1.71)$$

$$a_n = \frac{\omega}{\pi} \int_0^{2\pi/\omega} x(t) \cos n\omega t dt = \frac{2}{\tau} \int_0^\tau x(t) \cos n\omega t dt \quad (1.72)$$

$$b_n = \frac{\omega}{\pi} \int_0^{2\pi/\omega} x(t) \sin n\omega t dt = \frac{2}{\tau} \int_0^\tau x(t) \sin n\omega t dt \quad (1.73)$$

The physical interpretation of Eq. (1.70) is that any periodic function can be represented as a sum of harmonic functions. Although the series in Eq. (1.70) is an infinite sum, we can approximate most periodic functions with the help of only a few harmonic functions. For example, the triangular wave of Fig. 1.54(a) can be represented closely by adding only three harmonic functions, as shown in Fig. 1.54(b).

Fourier series can also be represented by the sum of sine terms only or cosine terms only. For example, the series using cosine terms only can be expressed as

$$x(t) = d_0 + d_1 \cos(\omega t - \phi_1) + d_2 \cos(2\omega t - \phi_2) + \dots \quad (1.74)$$

where

$$d_0 = a_0/2 \quad (1.75)$$

$$d_n = (a_n^2 + b_n^2)^{1/2} \quad (1.76)$$

and

$$\phi_n = \tan^{-1} \left(\frac{b_n}{a_n} \right) \quad (1.77)$$

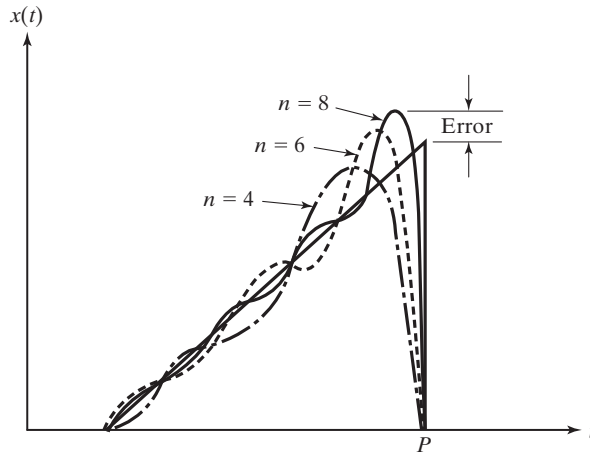

FIGURE 1.55 Gibbs' phenomenon.

Gibbs' Phenomenon. When a periodic function is represented by a Fourier series, an anomalous behavior can be observed. For example, Fig. 1.55 shows a triangular wave and its Fourier series representation using a different number of terms. As the number of terms (n) increases, the approximation can be seen to improve everywhere except in the vicinity of the discontinuity (point P in Fig. 1.55). Here the deviation from the true waveform becomes narrower but not any smaller in amplitude. It has been observed that the error in amplitude remains at approximately 9 percent, even when $k \rightarrow \infty$. This behavior is known as Gibbs' phenomenon, after its discoverer.

1.11.2 Complex Fourier Series

The Fourier series can also be represented in terms of complex numbers. By noting, from Eqs. (1.41) and (1.42), that

$$e^{i\omega t} = \cos \omega t + i \sin \omega t \quad (1.78)$$

and

$$e^{-i\omega t} = \cos \omega t - i \sin \omega t \quad (1.79)$$

$\cos \omega t$ and $\sin \omega t$ can be expressed as

$$\cos \omega t = \frac{e^{i\omega t} + e^{-i\omega t}}{2} \quad (1.80)$$

and

$$\sin \omega t = \frac{e^{i\omega t} - e^{-i\omega t}}{2i} \quad (1.81)$$

Thus Eq. (1.70) can be written as

$$\begin{aligned}
 x(t) &= \frac{a_0}{2} + \sum_{n=1}^{\infty} \left\{ a_n \left(\frac{e^{in\omega t} + e^{-in\omega t}}{2} \right) + b_n \left(\frac{e^{in\omega t} - e^{-in\omega t}}{2i} \right) \right\} \\
 &= e^{i(0)\omega t} \left(\frac{a_0}{2} - \frac{ib_0}{2} \right) \\
 &\quad + \sum_{n=1}^{\infty} \left\{ e^{in\omega t} \left(\frac{a_n}{2} - \frac{ib_n}{2} \right) + e^{-in\omega t} \left(\frac{a_n}{2} + \frac{ib_n}{2} \right) \right\}
 \end{aligned} \tag{1.82}$$

where $b_0 = 0$. By defining the complex Fourier coefficients c_n and c_{-n} as

$$c_n = \frac{a_n - ib_n}{2} \tag{1.83}$$

and

$$c_{-n} = \frac{a_n + ib_n}{2} \tag{1.84}$$

Eq. (1.82) can be expressed as

$$x(t) = \sum_{n=-\infty}^{\infty} c_n e^{in\omega t} \tag{1.85}$$

The Fourier coefficients c_n can be determined, using Eqs. (1.71) to (1.73), as

$$\begin{aligned}
 c_n &= \frac{a_n - ib_n}{2} = \frac{1}{\tau} \int_0^{\tau} x(t) [\cos n\omega t - i \sin n\omega t] dt \\
 &= \frac{1}{\tau} \int_0^{\tau} x(t) e^{-in\omega t} dt
 \end{aligned} \tag{1.86}$$

1.11.3 Frequency Spectrum

The harmonic functions $a_n \cos n\omega t$ or $b_n \sin n\omega t$ in Eq. (1.70) are called the *harmonics* of order n of the periodic function $x(t)$. The harmonic of order n has a period τ/n . These harmonics can be plotted as vertical lines on a diagram of amplitude (a_n and b_n or d_n and ϕ_n) versus frequency ($n\omega$), called the *frequency spectrum* or *spectral diagram*. Figure 1.56 shows a typical frequency spectrum.

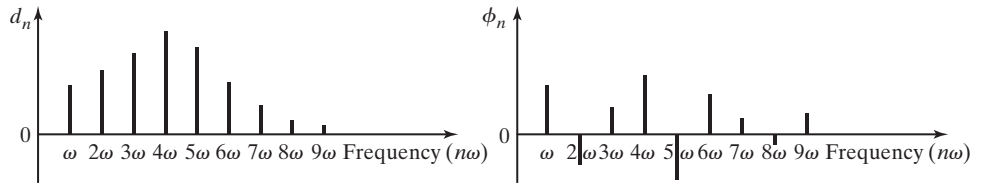

FIGURE 1.56 Frequency spectrum of a typical periodic function of time.

**1.11.4
Time- and
Frequency-
Domain
Representations**

The Fourier series expansion permits the description of any periodic function using either a time-domain or a frequency-domain representation. For example, a harmonic function given by $x(t) = A \sin \omega t$ in time domain (see Fig. 1.57(a)) can be represented by the amplitude and the frequency ω in the frequency domain (see Fig. 1.57(b)). Similarly, a periodic function, such as a triangular wave, can be represented in time domain, as shown in Fig. 1.57(c), or in frequency domain, as indicated in Fig. 1.57(d). Note that the amplitudes d_n and the phase angles ϕ_n corresponding to the frequencies ω_n can be used in place of the amplitudes a_n and b_n for representation in the frequency domain. Using a Fourier integral (considered in Section 14.9) permits the representation of even nonperiodic functions in

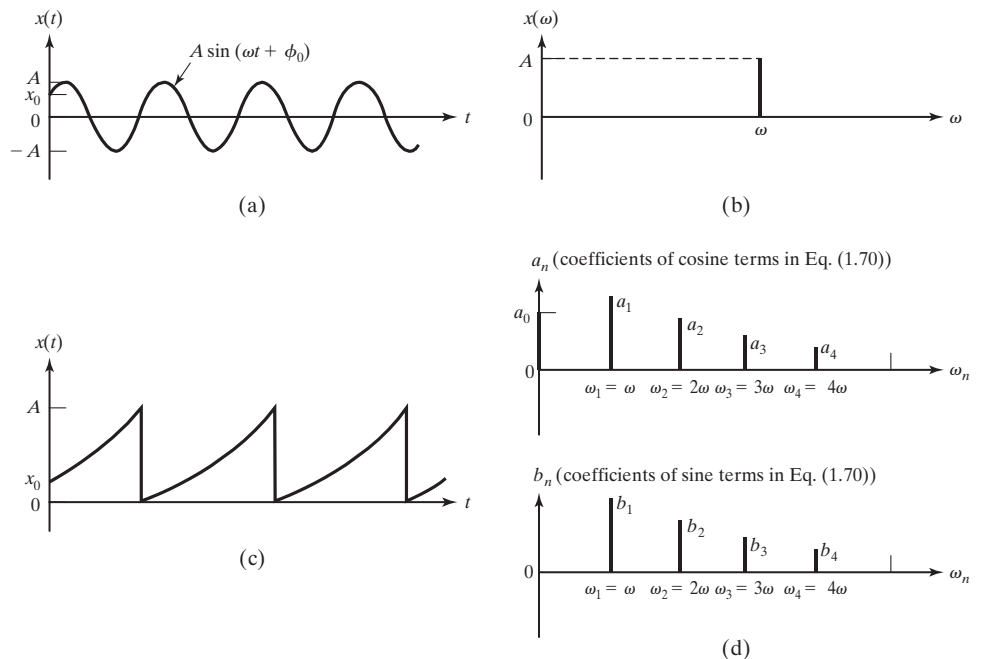

FIGURE 1.57 Representation of a function in time and frequency domains.

either a time domain or a frequency domain. Figure 1.57 shows that the frequency-domain representation does not provide the initial conditions. However, in many practical applications the initial conditions are often considered unnecessary and only the steady-state conditions are of main interest.

1.11.5 Even and Odd Functions

An even function satisfies the relation

$$x(-t) = x(t) \quad (1.87)$$

In this case, the Fourier series expansion of $x(t)$ contains only cosine terms:

$$x(t) = \frac{a_0}{2} + \sum_{n=1}^{\infty} a_n \cos n\omega t \quad (1.88)$$

where a_0 and a_n are given by Eqs. (1.71) and (1.72), respectively. An odd function satisfies the relation

$$x(-t) = -x(t) \quad (1.89)$$

In this case, the Fourier series expansion of $x(t)$ contains only sine terms:

$$x(t) = \sum_{n=1}^{\infty} b_n \sin n\omega t \quad (1.90)$$

where b_n is given by Eq. (1.73). In some cases, a given function may be considered as even or odd depending on the location of the coordinate axes. For example, the shifting of the vertical axis from (a) to (b) or (c) in Fig. 1.58(i) will make it an odd or even function. This means that we need to compute only the coefficients b_n or a_n . Similarly, a shift in the time axis from (d) to (e) amounts to adding a constant equal to the amount of shift. In the case of Fig. 1.58(ii), when the function is considered as an odd function, the Fourier series expansion becomes (see Problem 1.107):

$$x_1(t) = \frac{4A}{\pi} \sum_{n=1}^{\infty} \frac{1}{(2n-1)} \sin \frac{2\pi(2n-1)t}{\tau} \quad (1.91)$$

On the other hand, if the function is considered an even function, as shown in Fig. 1.50(iii), its Fourier series expansion becomes (see Problem 1.107):

$$x_2(t) = \frac{4A}{\pi} \sum_{n=1}^{\infty} \frac{(-1)^{n+1}}{(2n-1)} \cos \frac{2\pi(2n-1)t}{\tau} \quad (1.92)$$

Since the functions $x_1(t)$ and $x_2(t)$ represent the same wave, except for the location of the origin, there exists a relationship between their Fourier series expansions also. Noting that

$$x_1\left(t + \frac{\tau}{4}\right) = x_2(t) \quad (1.93)$$

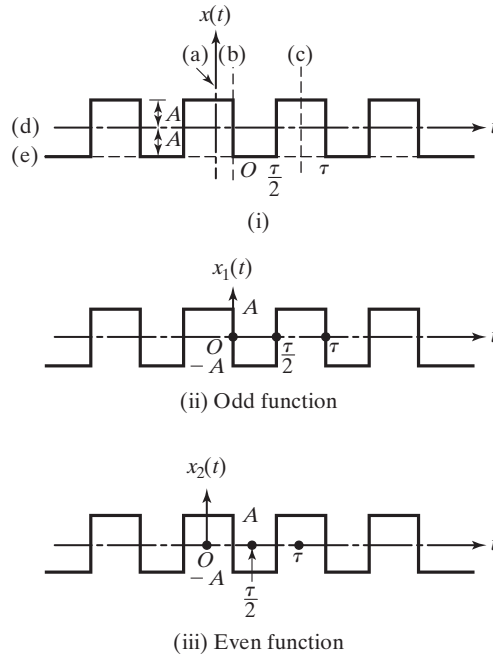

FIGURE 1.58 Even and odd functions.

we find from Eq. (1.91),

$$\begin{aligned}
 x_1\left(t + \frac{\tau}{4}\right) &= \frac{4A}{\pi} \sum_{n=1}^{\infty} \frac{1}{(2n-1)} \sin \frac{2\pi(2n-1)}{\tau} \left(t + \frac{\tau}{4}\right) \\
 &= \frac{4A}{\pi} \sum_{n=1}^{\infty} \frac{1}{(2n-1)} \sin \left\{ \frac{2\pi(2n-1)t}{\tau} + \frac{2\pi(2n-1)}{4} \right\} \quad (1.94)
 \end{aligned}$$

Using the relation $\sin(A + B) = \sin A \cos B + \cos A \sin B$, Eq. (1.94) can be expressed as

$$\begin{aligned}
 x_1\left(t + \frac{\tau}{4}\right) &= \frac{4A}{\pi} \sum_{n=1}^{\infty} \left\{ \frac{1}{(2n-1)} \sin \frac{2\pi(2n-1)t}{\tau} \cos \frac{2\pi(2n-1)}{4} \right. \\
 &\quad \left. + \cos \frac{2\pi(2n-1)t}{\tau} \sin \frac{2\pi(2n-1)}{4} \right\} \quad (1.95)
 \end{aligned}$$

Since $\cos [2\pi(2n - 1)/4] = 0$ for $n = 1, 2, 3, \dots$, and $\sin [2\pi(2n - 1)/4] = (-1)^{n+1}$ for $n = 1, 2, 3, \dots$, Eq. (1.95) reduces to

$$x_1\left(t + \frac{\tau}{4}\right) = \frac{4A}{\pi} \sum_{n=1}^{\infty} \frac{(-1)^{n+1}}{(2n - 1)} \cos \frac{2\pi(2n - 1)t}{\tau} \quad (1.96)$$

which can be identified to be the same as Eq. (1.92).

1.11.6 Half-Range Expansions

In some practical applications, the function $x(t)$ is defined only in the interval 0 to τ as shown in Fig. 1.59(a). In such a case, there is no condition of periodicity of the function, since the function itself is not defined outside the interval 0 to τ . However, we can extend the function arbitrarily to include the interval $-\tau$ to 0 as shown in either Fig. 1.59(b) or Fig. 1.59(c). The extension of the function indicated in Fig. 1.59(b) results in an odd function, $x_1(t)$, while the extension of the function shown in Fig. 1.59(c) results in an even function, $x_2(t)$. Thus the Fourier series expansion of $x_1(t)$ yields only sine terms and that of $x_2(t)$ involves only cosine terms. These Fourier series expansions of $x_1(t)$ and $x_2(t)$ are

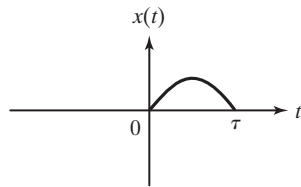

(a) Original function

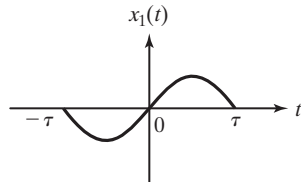

(b) Extension as an odd function

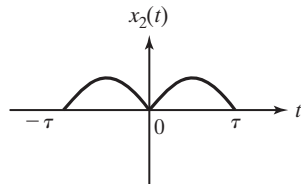

(c) Extension as an even function

FIGURE 1.59 Extension of a function for half-range expansions.

known as half-range expansions [1.37]. Any of these half-range expansions can be used to find $x(t)$ in the interval 0 to τ .

1.11.7 Numerical Computation of Coefficients

For very simple forms of the function $x(t)$, the integrals of Eqs. (1.71) to (1.73) can be evaluated easily. However, the integration becomes involved if $x(t)$ does not have a simple form. In some practical applications, as in the case of experimental determination of the amplitude of vibration using a vibration transducer, the function $x(t)$ is not available in the form of a mathematical expression; only the values of $x(t)$ at a number of points t_1, t_2, \dots, t_N are available, as shown in Fig. 1.60. In these cases, the coefficients a_n and b_n of Eqs. (1.71) to (1.73) can be evaluated by using a numerical integration procedure like the trapezoidal or Simpson's rule [1.38].

Let's assume that t_1, t_2, \dots, t_N are an even number of equidistant points over the period τ ($N = \text{even}$) with the corresponding values of $x(t)$ given by $x_1 = x(t_1)$, $x_2 = x(t_2)$, \dots , $x_N = x(t_N)$, respectively; then the application of the trapezoidal rule gives the coefficients a_n and b_n (by setting $\tau = N\Delta t$) as:⁶

$$a_0 = \frac{2}{N} \sum_{i=1}^N x_i \tag{1.97}$$

$$a_n = \frac{2}{N} \sum_{i=1}^N x_i \cos \frac{2n\pi t_i}{\tau} \tag{1.98}$$

$$b_n = \frac{2}{N} \sum_{i=1}^N x_i \sin \frac{2n\pi t_i}{\tau} \tag{1.99}$$

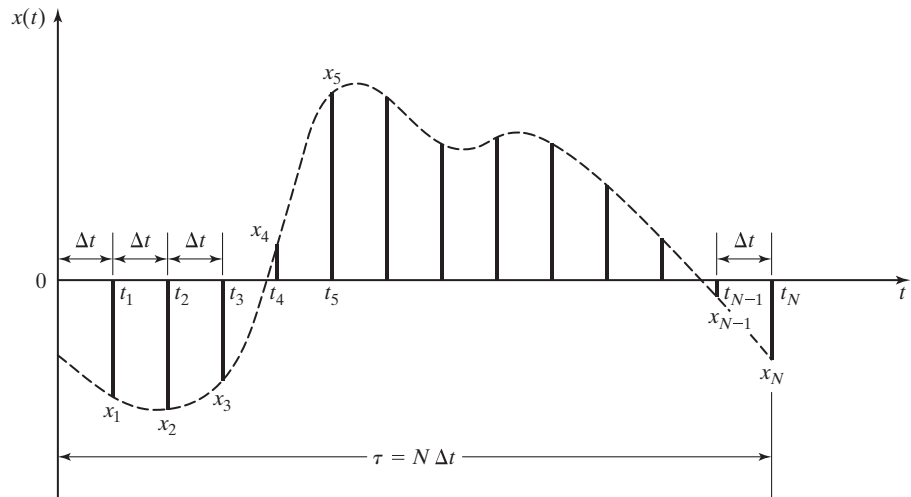

FIGURE 1.60 Values of the periodic function $x(t)$ at discrete points t_1, t_2, \dots, t_N .

⁶ N Needs to be an even number for Simpson's rule but not for the trapezoidal rule. Equations (1.97) to (1.99) assume that the periodicity condition, $x_0 = x_N$, holds true.

EXAMPLE 1.19 Fourier Series Expansion

Determine the Fourier series expansion of the motion of the valve in the cam-follower system shown in Fig. 1.61.

Solution: If $y(t)$ denotes the vertical motion of the pushrod, the motion of the valve, $x(t)$, can be determined from the relation:

$$\tan \theta = \frac{y(t)}{l_1} = \frac{x(t)}{l_2}$$

or

$$x(t) = \frac{l_2}{l_1} y(t) \quad (\text{E.1})$$

where

$$y(t) = Y \frac{t}{\tau}, \quad 0 \leq t \leq \tau \quad (\text{E.2})$$

and the period is given by $\tau = \frac{2\pi}{\omega}$. By defining

$$A = \frac{Y l_2}{l_1}$$

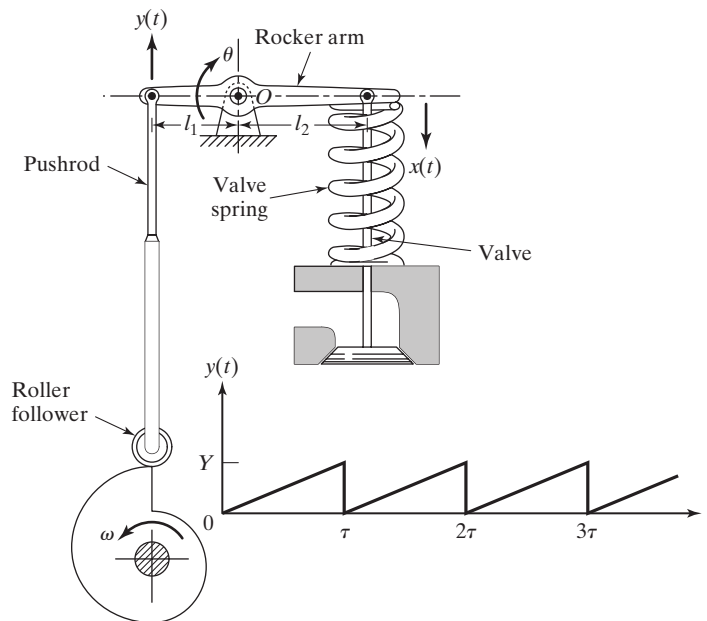

FIGURE 1.61 Cam-follower system.

$x(t)$ can be expressed as

$$x(t) = A \frac{t}{\tau}; \quad 0 \leq t \leq \tau \tag{E.3}$$

Equation (E.3) is shown in Fig. 1.54(a). To compute the Fourier coefficients a_n and b_n , we use Eqs. (1.71) to (1.73):

$$a_0 = \frac{\omega}{\pi} \int_0^{2\pi/\omega} x(t) dt = \frac{\omega}{\pi} \int_0^{2\pi/\omega} A \frac{t}{\tau} dt = \frac{\omega}{\pi} \frac{A}{\tau} \left(\frac{t^2}{2} \right)_0^{2\pi/\omega} = A \tag{E.4}$$

$$\begin{aligned} a_n &= \frac{\omega}{\pi} \int_0^{2\pi/\omega} x(t) \cos n\omega t \cdot dt = \frac{\omega}{\pi} \int_0^{2\pi/\omega} A \frac{t}{\tau} \cos n\omega t \cdot dt \\ &= \frac{A\omega}{\pi\tau} \int_0^{2\pi/\omega} t \cos n\omega t \cdot dt = \frac{A}{2\pi^2} \left[\frac{\cos n\omega t}{n^2} + \frac{\omega t \sin n\omega t}{n} \right]_0^{2\pi/\omega} \\ &= 0, \quad n = 1, 2, \dots \end{aligned} \tag{E.5}$$

$$\begin{aligned} b_n &= \frac{\omega}{\pi} \int_0^{2\pi/\omega} x(t) \sin n\omega t \cdot dt = \frac{\omega}{\pi} \int_0^{2\pi/\omega} A \frac{t}{\tau} \sin n\omega t \cdot dt \\ &= \frac{A\omega}{\pi\tau} \int_0^{2\pi/\omega} t \sin n\omega t \cdot dt = \frac{A}{2\pi^2} \left[\frac{\sin n\omega t}{n^2} - \frac{\omega t \cos n\omega t}{n} \right]_0^{2\pi/\omega} \\ &= -\frac{A}{n\pi}, \quad n = 1, 2, \dots \end{aligned} \tag{E.6}$$

Therefore the Fourier series expansion of $x(t)$ is

$$\begin{aligned} x(t) &= \frac{A}{2} - \frac{A}{\pi} \sin \omega t - \frac{A}{2\pi} \sin 2 \omega t - \dots \\ &= \frac{A}{\pi} \left[\frac{\pi}{2} - \left\{ \sin \omega t + \frac{1}{2} \sin 2\omega t + \frac{1}{3} \sin 3\omega t + \dots \right\} \right] \end{aligned} \tag{E.7}$$

The first three terms of the series are shown plotted in Fig. 1.54(b). It can be seen that the approximation reaches the sawtooth shape even with a small number of terms. ■

EXAMPLE 1.20 Numerical Fourier Analysis

The pressure fluctuations of water in a pipe, measured at 0.01-second intervals, are given in Table 1.1. These fluctuations are repetitive in nature. Make a harmonic analysis of the pressure fluctuations and determine the first three harmonics of the Fourier series expansion.

TABLE 1.1

Time Station, i	Time (sec), t_i	Pressure (kN/m ²), p_i
0	0	0
1	0.01	20
2	0.02	34
3	0.03	42
4	0.04	49
5	0.05	53
6	0.06	70
7	0.07	60
8	0.08	36
9	0.09	22
10	0.10	16
11	0.11	7
12	0.12	0

Solution: Since the given pressure fluctuations repeat every 0.12 sec, the period is $\tau = 0.12$ sec and the circular frequency of the first harmonic is 2π radians per 0.12 sec or $\omega = 2\pi/0.12 = 52.36$ rad/sec. As the number of observed values in each wave (N) is 12, we obtain from Eq. (1.97)

$$a_0 = \frac{2}{N} \sum_{i=1}^N p_i = \frac{1}{6} \sum_{i=1}^{12} p_i = 68166.7 \quad (\text{E.1})$$

The coefficients a_n and b_n can be determined from Eqs. (1.98) and (1.99):

$$a_n = \frac{2}{N} \sum_{i=1}^N p_i \cos \frac{2n\pi t_i}{\tau} = \frac{1}{6} \sum_{i=1}^{12} p_i \cos \frac{2n\pi t_i}{0.12} \quad (\text{E.2})$$

$$b_n = \frac{2}{N} \sum_{i=1}^N p_i \sin \frac{2n\pi t_i}{\tau} = \frac{1}{6} \sum_{i=1}^{12} p_i \sin \frac{2n\pi t_i}{0.12} \quad (\text{E.3})$$

The computations involved in Eqs. (E.2) and (E.3) are shown in Table 1.2. From these calculations, the Fourier series expansion of the pressure fluctuations $p(t)$ can be obtained (see Eq. 1.70):

$$\begin{aligned} p(t) = & 34083.3 - 26996.0 \cos 52.36t + 8307.7 \sin 52.36t \\ & + 1416.7 \cos 104.72t + 3608.3 \sin 104.72t - 5833.3 \cos 157.08t \\ & - 2333.3 \sin 157.08t + \cdots \quad \text{N/m}^2 \end{aligned} \quad (\text{E.4})$$

TABLE 1.2

i	t_i	p_i	$n = 1$		$n = 2$		$n = 3$	
			$p_i \cos \frac{2\pi t_i}{0.12}$	$p_i \sin \frac{2\pi t_i}{0.12}$	$p_i \cos \frac{4\pi t_i}{0.12}$	$p_i \sin \frac{4\pi t_i}{0.12}$	$p_i \cos \frac{6\pi t_i}{0.12}$	$p_i \sin \frac{6\pi t_i}{0.12}$
1	0.01	20000	17320	10000	10000	17320	0	20000
2	0.02	34000	17000	29444	-17000	29444	-34000	0
3	0.03	42000	0	42000	-42000	0	0	-42000
4	0.04	49000	-24500	42434	-24500	-42434	49000	0
5	0.05	53000	-45898	26500	26500	-45898	0	53000
6	0.06	70000	-70000	0	70000	0	-70000	0
7	0.07	60000	-51960	-30000	30000	51960	0	-60000
8	0.08	36000	-18000	-31176	-18000	31176	36000	0
9	0.09	22000	0	-22000	-22000	0	0	22000
10	0.10	16000	8000	-13856	-8000	-13856	-16000	0
11	0.11	7000	6062	-3500	3500	-6062	0	-7000
12	0.12	0	0	0	0	0	0	0
$\sum_{i=1}^{12}()$		409000	-161976	49846	8500	21650	-35000	-14000
$\frac{1}{6} \sum_{i=1}^{12}()$		68166.7	-26996.0	8307.7	1416.7	3608.3	-5833.3	-2333.3

1.12 Examples Using MATLAB⁷

Graphical Representation of Fourier Series Using MATLAB

EXAMPLE 1.21

Plot the periodic function

$$x(t) = A \frac{t}{\tau}, \quad 0 \leq t \leq \tau \quad (\text{E.1})$$

and its Fourier series representation with four terms

$$\bar{x}(t) = \frac{A}{\pi} \left\{ \frac{\pi}{2} - \left(\sin \omega t + \frac{1}{2} \sin 2\omega t + \frac{1}{3} \sin 3\omega t \right) \right\} \quad (\text{E.2})$$

for $0 \leq t \leq \tau$ with $A = 1$, $\omega = \pi$, and $\tau = \frac{2\pi}{\omega} = 2$.

⁷The source codes of all MATLAB programs are given at the Companion Website.