

La Classificazione Tipologica ...

*... Coordinate Teoriche,
Consigli Pratici &
Trucchi
per affrontarla
al meglio !*



Agostino Sotgia
agostino.sotgia@uniroma1.it
Sapienza – Università di Roma
RUG - University of Groningen



Seminario di 20 ore per il corso di studi in Lettere, Arte, Archeologia (L-10)
Metodi e Pratiche di Studio della Cultura Materiale
Oggetti, Contesti e Storie per conoscere il territorio
24-05-2022

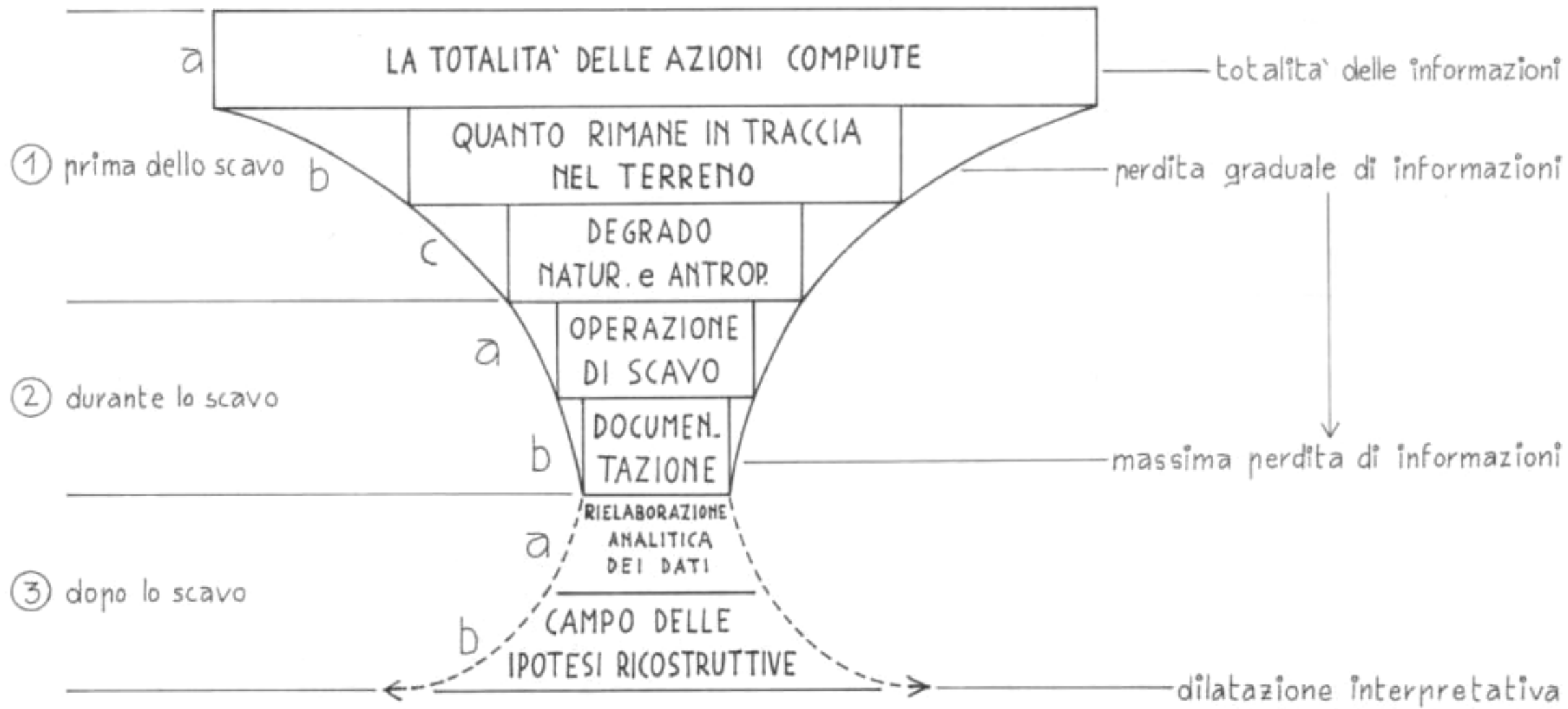

G. Leonardi 1982



*E' il destino dell'archeologo
quello di vedere frustrati
anni e anni di lavoro e ricerche*

I predatori dell'arca perduta - 1981

*L'archeologia si dedica alla ricerca dei
fatti, non delle verità. Se vi interessa la
verità, l'aula di filosofia del Professor
Tyre è in fondo al corridoio*

Indiana Jones e l'ultima crociata - 1989



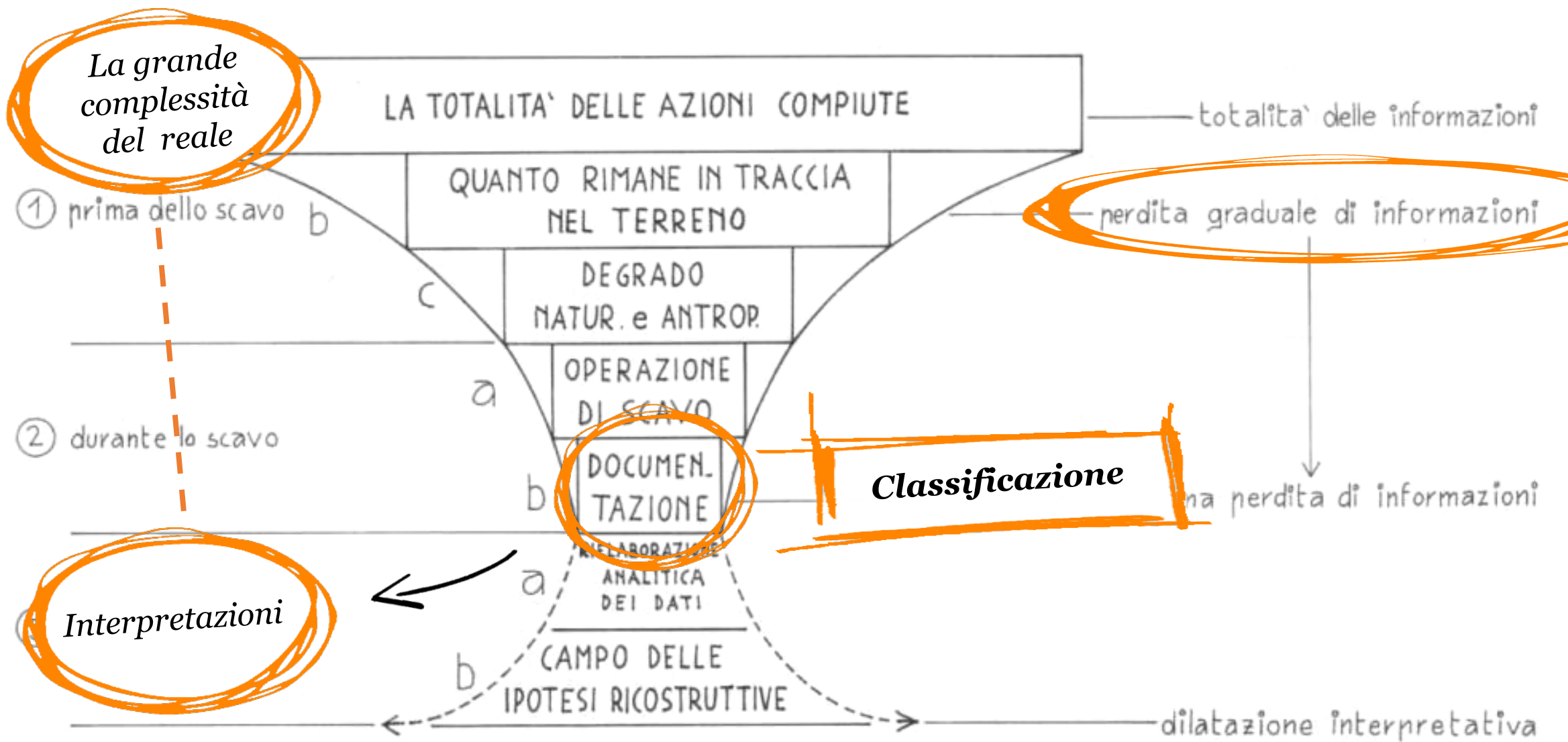

G. Leonardi 1982

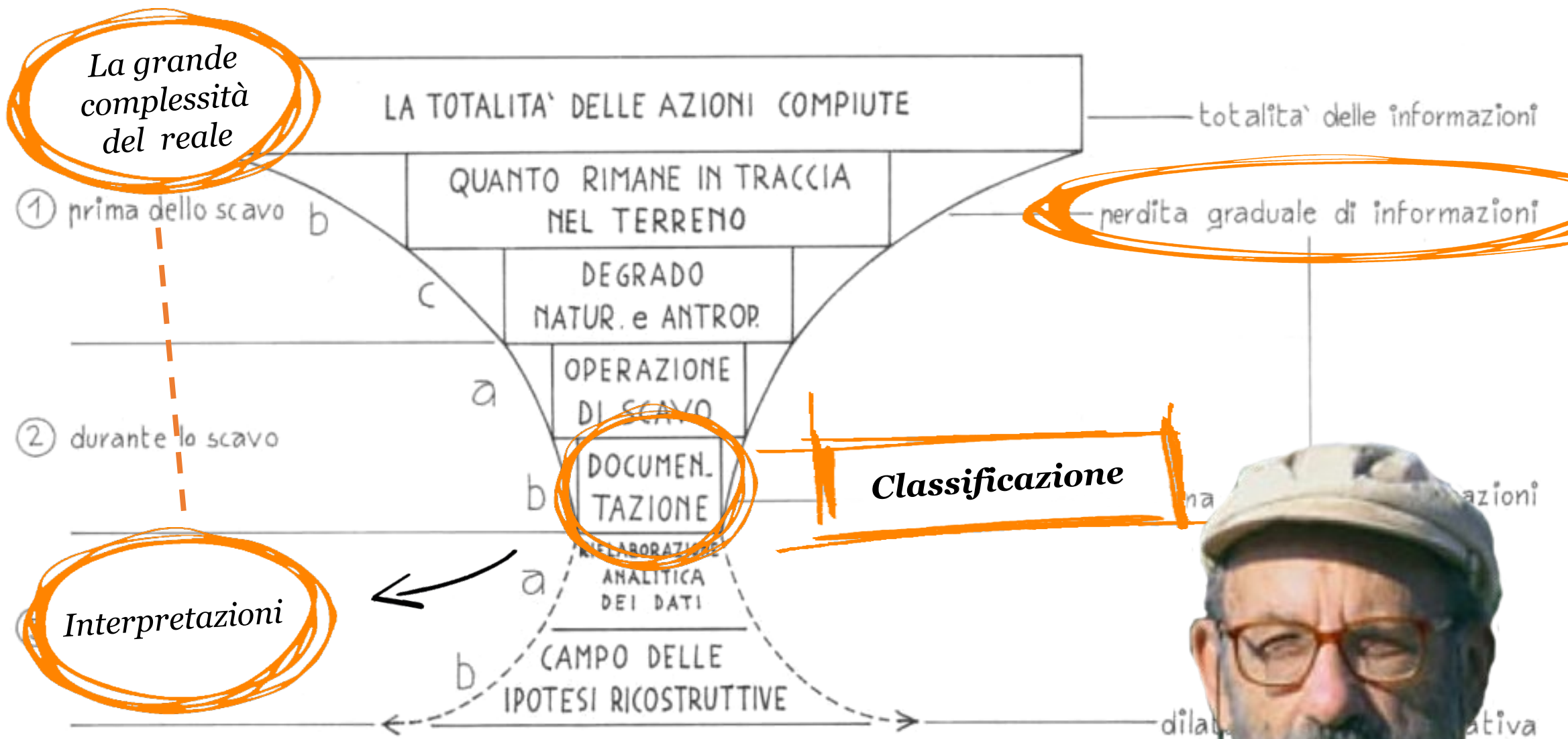

G. Leonardi 1982

La classificazione delle fonti archeologiche costituisce il momento decisivo ai fini dell'individuazione delle loro specifiche qualità informative » (PERONI 1994)

Esempi di Classificazioni:

Posizioni degli abitati italiani dell'età del Bronzo
(DI GENNARO 1996)

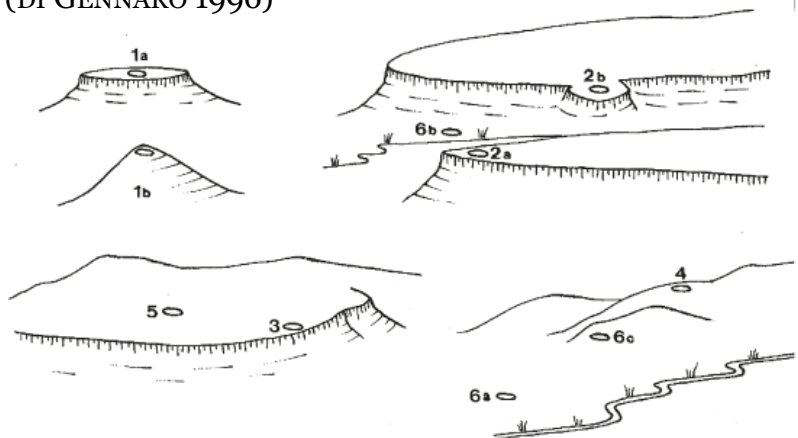

Strutture Abitative

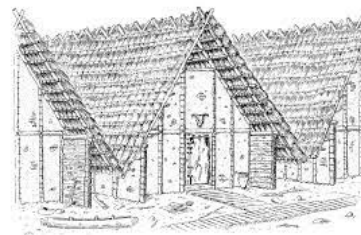
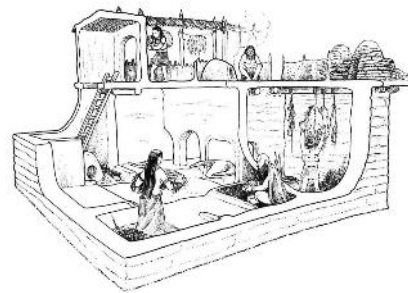

Fornaci protostoriche Italiane per la cottura del vasellame ceramico (SOTGIA 2019)

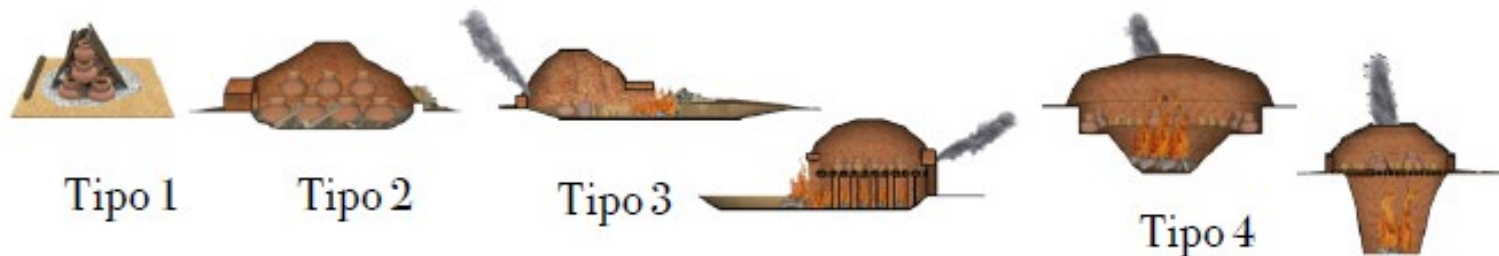

Reperti ceramici vascolari

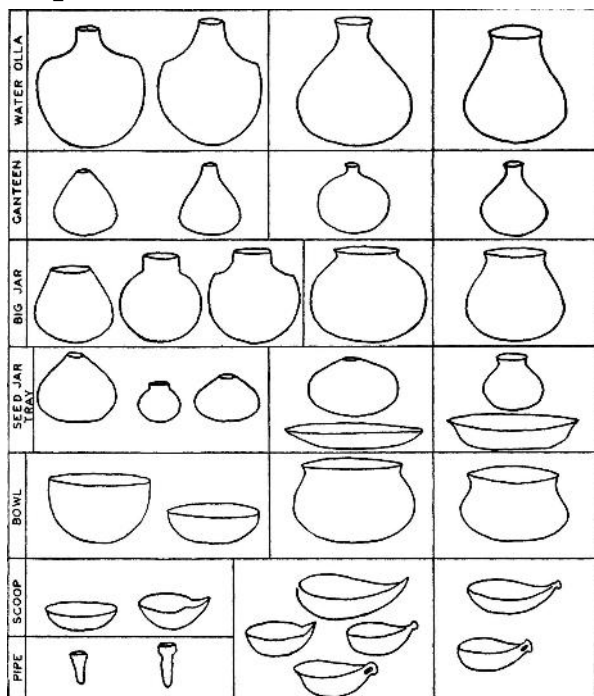

(RENFREW, BAHN 2009)

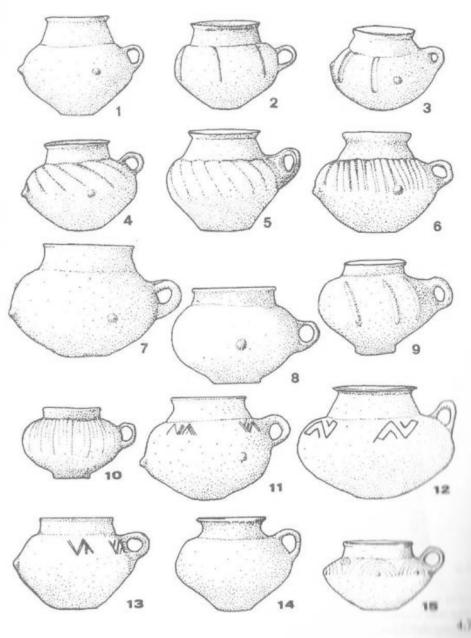

Orcioli - (PERONI 1994)



Anfore - (DRESSEL 1899)

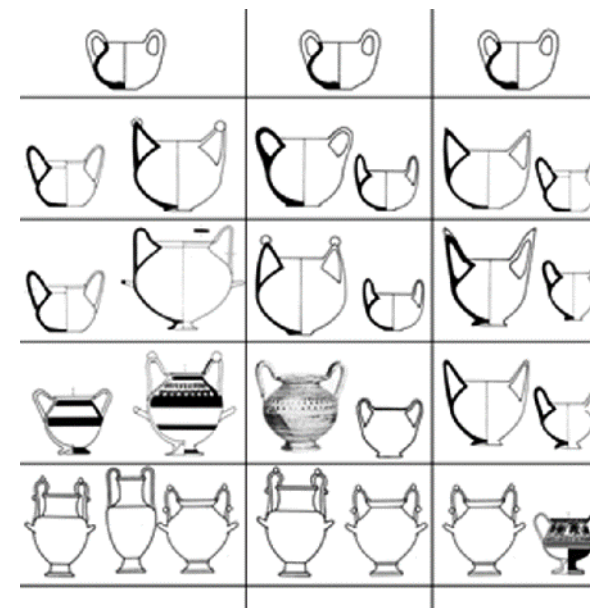

Esempi di Classificazioni:

Posizioni degli abitati italiani dell'età del Bronzo
(DI GENNARO 1996)

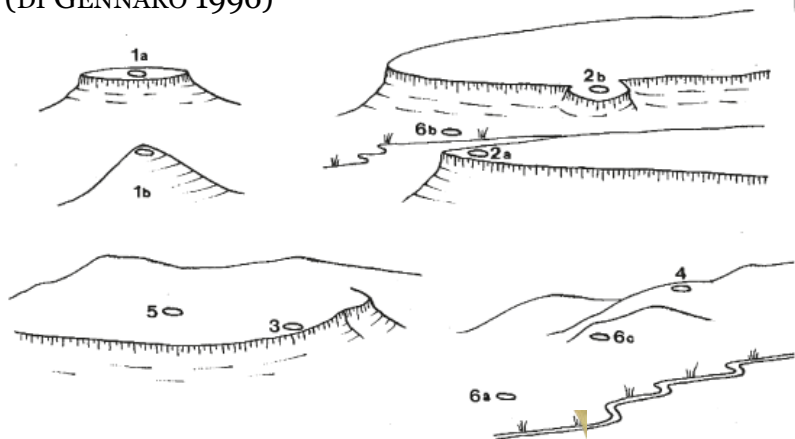

Strutture Abitative

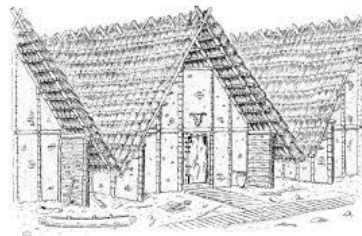
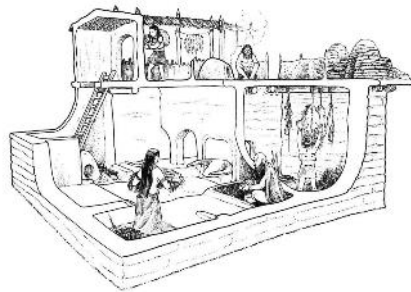

Fornaci protostoriche Italiane per la cottura del vasellame ceramico (SOTGIA 2019)

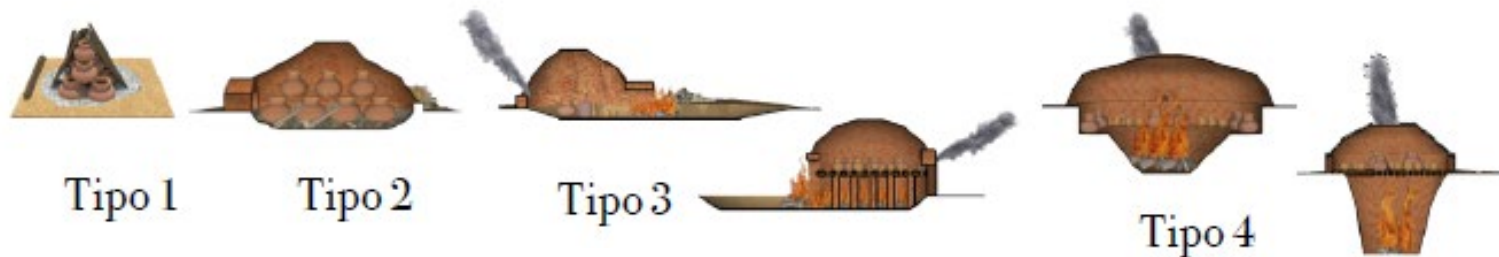

Reperti ceramici italiani

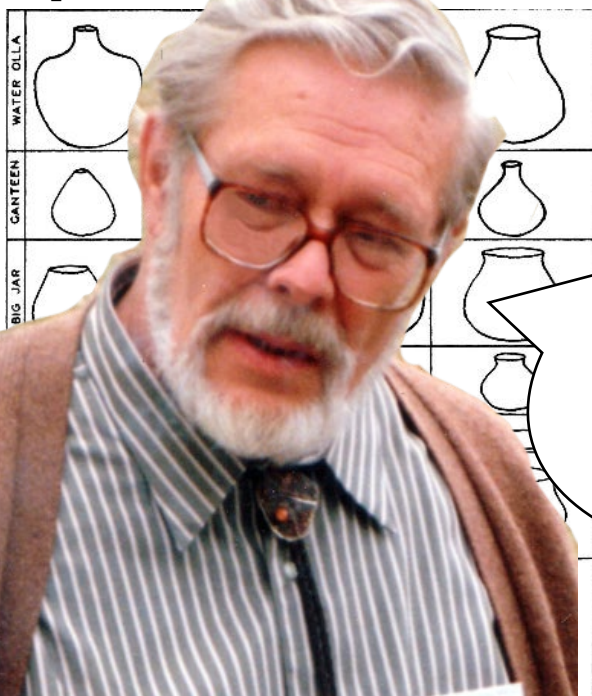

Tremendous Quantities !

Orcioli - (PERONI 1994)

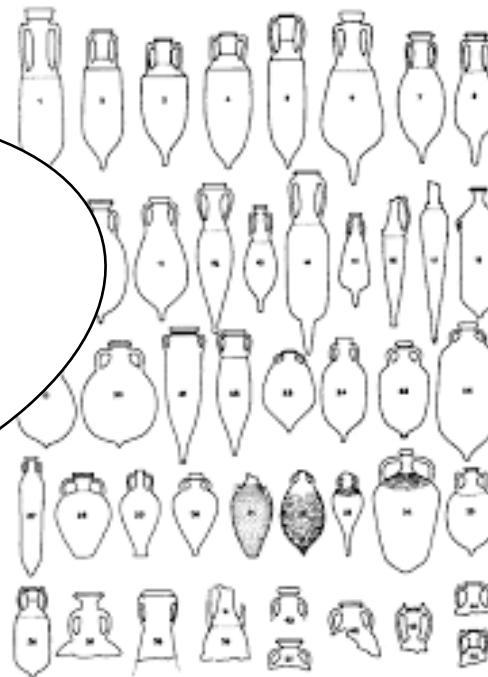

Anfore - (DRESSEL 1899)

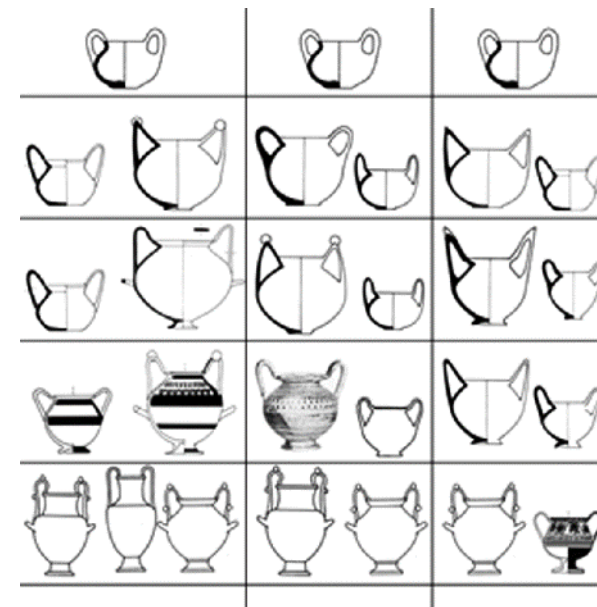

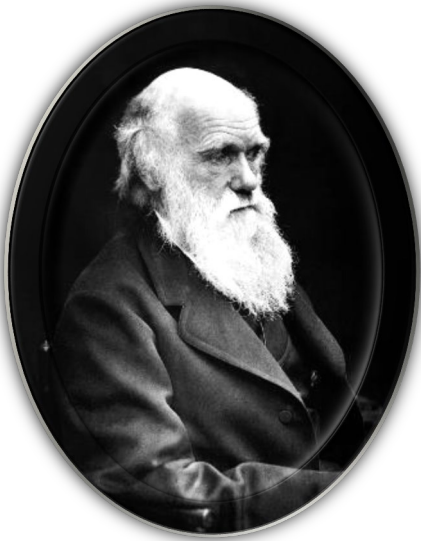

«Vi è qualcosa di grandioso in questa visione della vita con le sue numerose forze di crescita, di riproduzione e di senso, **originariamente impresse nella materia in poche forme**, forse soltanto in una, e nel fatto che, mentre questo pianeta continuava a girare secondo le leggi immutabili della gravità e mentre la terra e l'acqua si sostituivano l'una all'altra da un'origine così semplice, attraverso la selezione di **infinitesime varietà**, si evolvevano **innumerevoli forme le più belle e le più meravigliose**»

Charles Darwin, 1859, *Sull'Origine delle Specie* (Explicit)

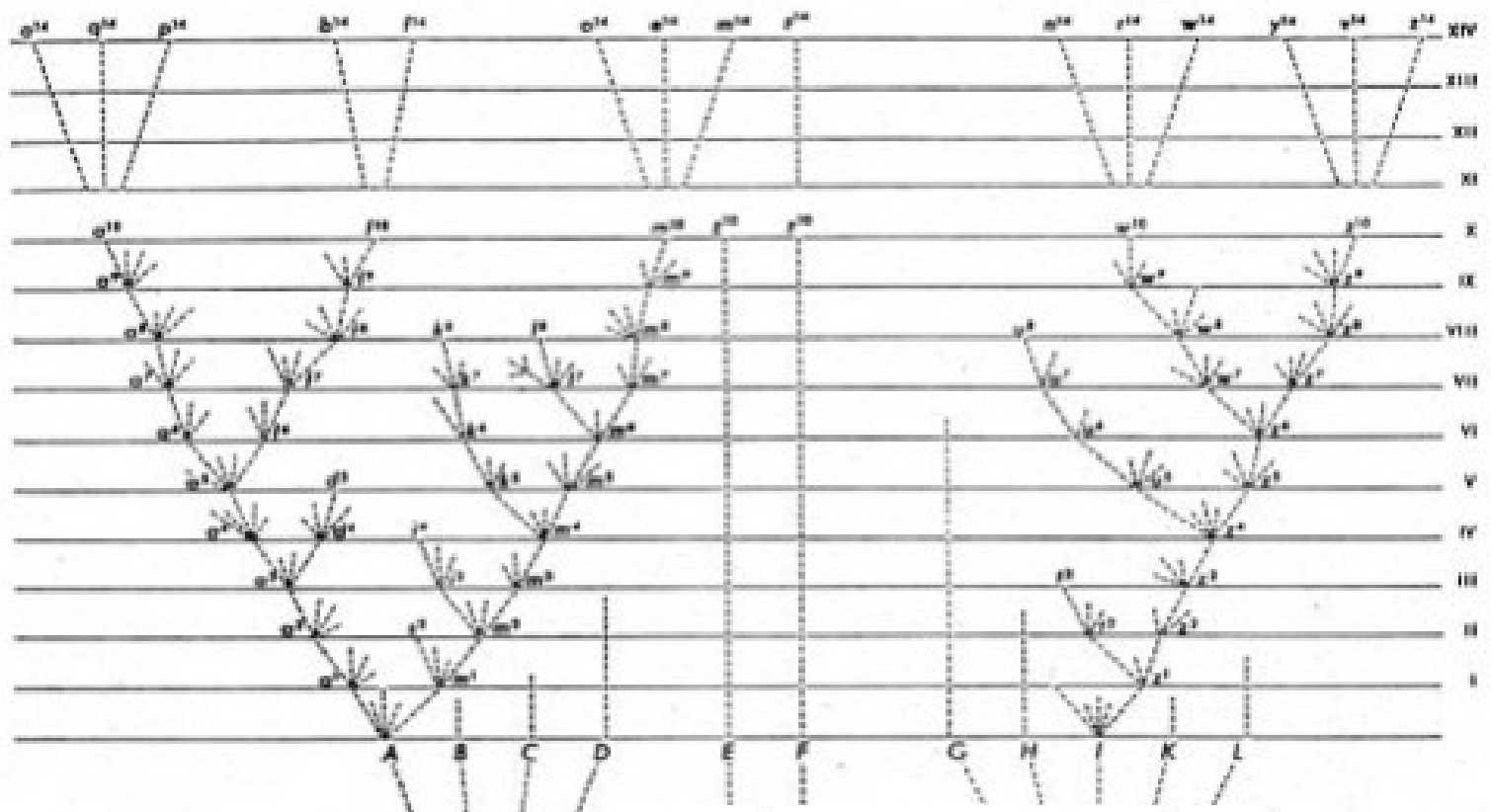

C. J. THOMSEN.



1836 - Ledetraad til Nordisk Oldkyndighed



Mezzi di trasporto

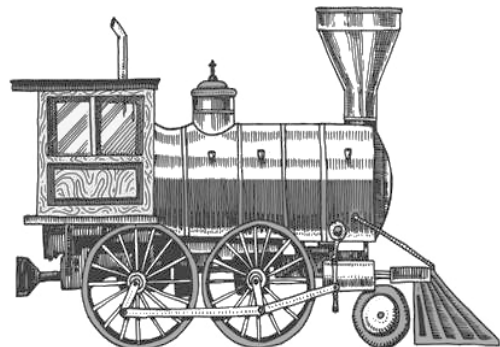
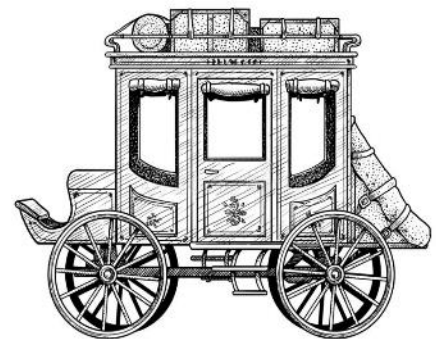
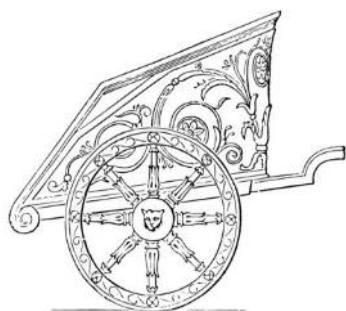

Asce

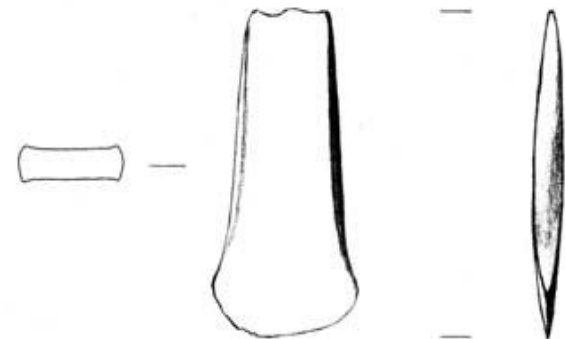
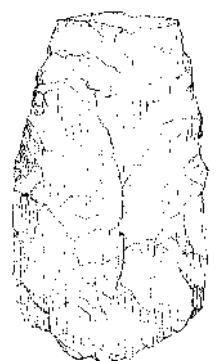

Telefoni



Organizzativo

Come si procede a classificare un insieme di dati ?

Attributi sempre più esclusivi

Tipi

Classificazione = Tipologia

Che genere di **Caratteristiche**

devono considerare ?

Estetiche

(es.) colore delle superfici, ...

Formali

(es.) Aperta/Chiusa, forma dell'orlo, ...

Funzionali

(es.) vaso per bere, mangiare, ...

Tecnologiche

(es.) uso del tornio o no, ...

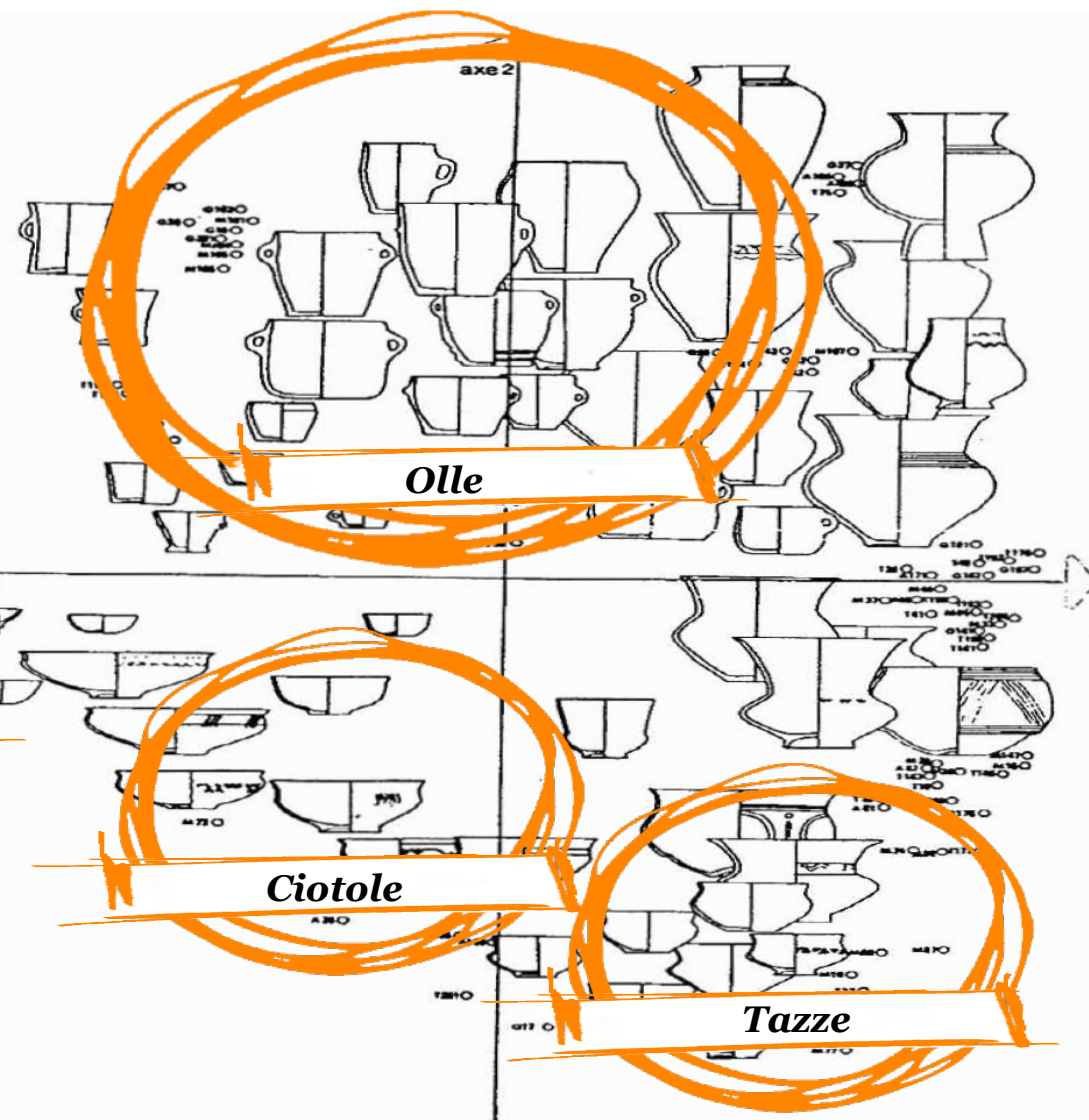

Tassonomia

Gerarchia di caratteristiche che descrivono ed ordinano gli elementi secondo regole di supremazia o subordinazione

Struttura gerarchica di una tipologia

I **Categoria**

Definita mediante le più evidenti e immediate analogie tra gli esemplari
(es.) *materia prima, generiche caratteristiche funzionali*

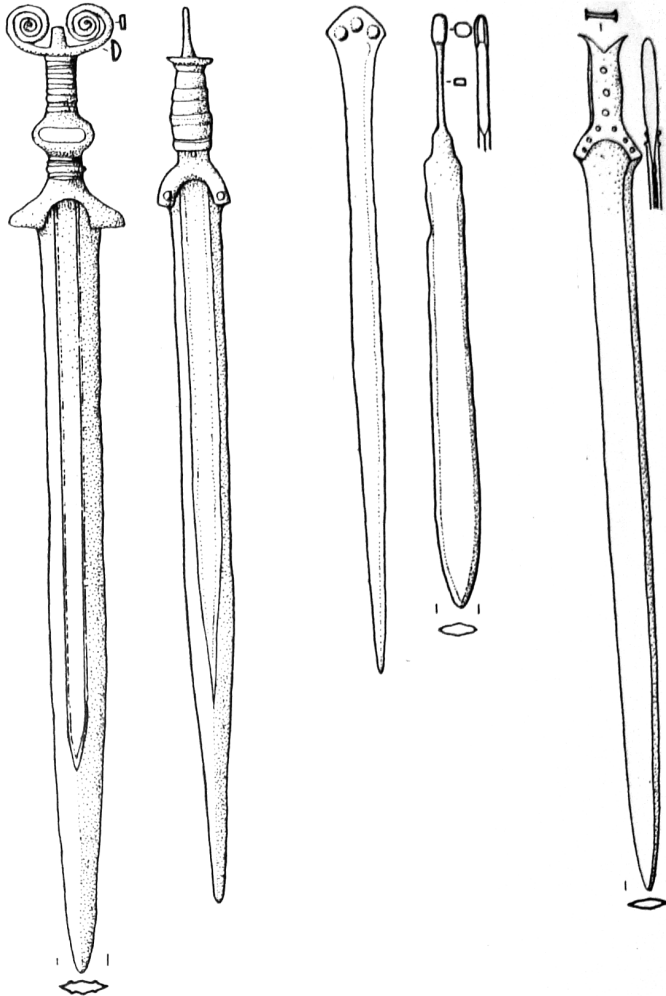

Spade (PERONI 1994)

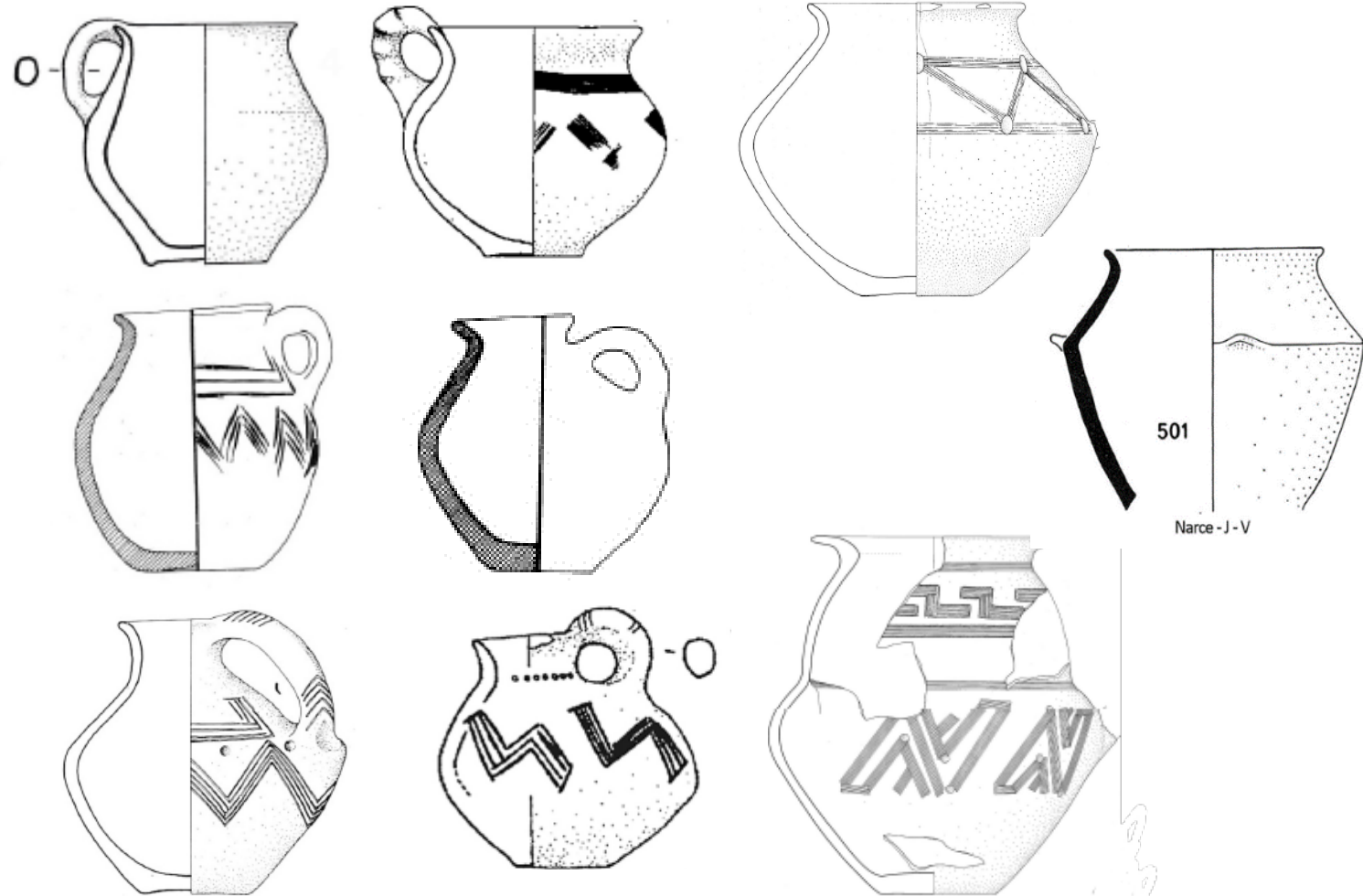

Brocche (SOTGIA 2015-2016)

Urne (SOTGIA 2015-2016)

Struttura gerarchica di una tipologia

I **Categoria**

II **Classe**

Contraddistinta da macroscopici attributi morfologici e funzionali
(es.) modo in cui è immanicata l'arma o un vaso svolge la sua funzione

(PERONI 1994)

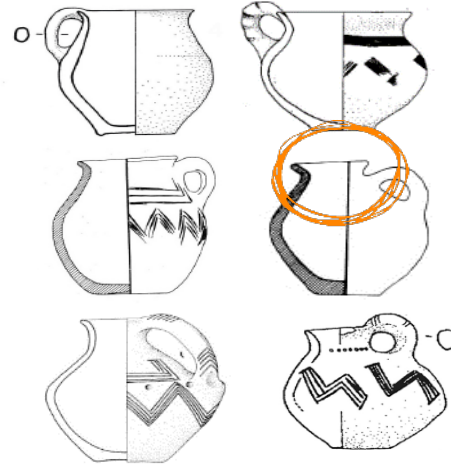
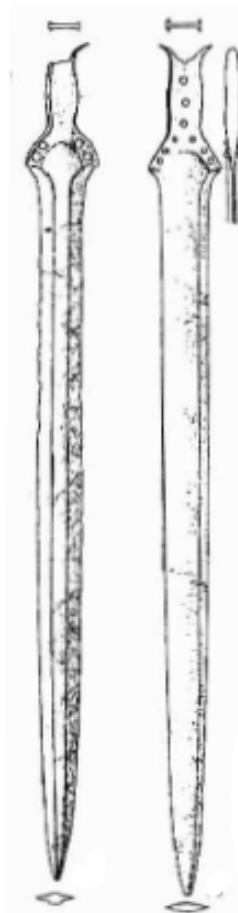
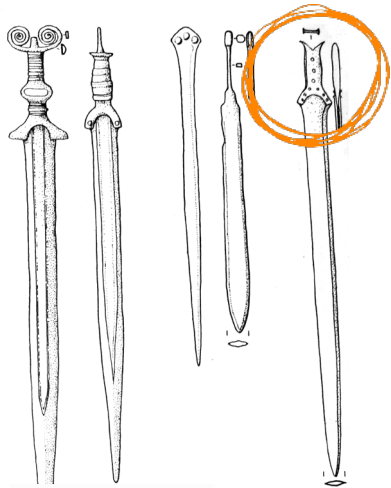

(SOTGIA 2015-2016)

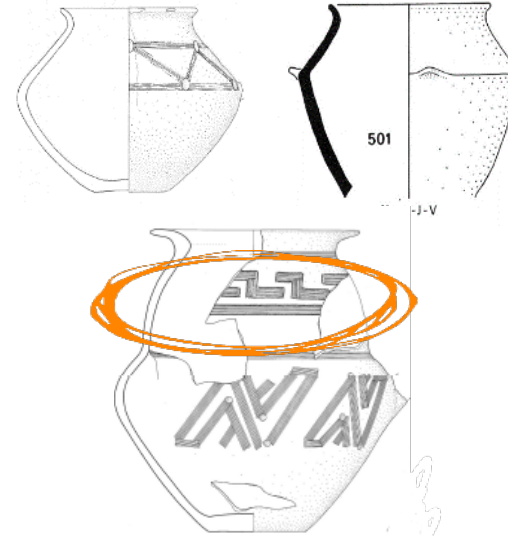

(SOTGIA 2015-2016)

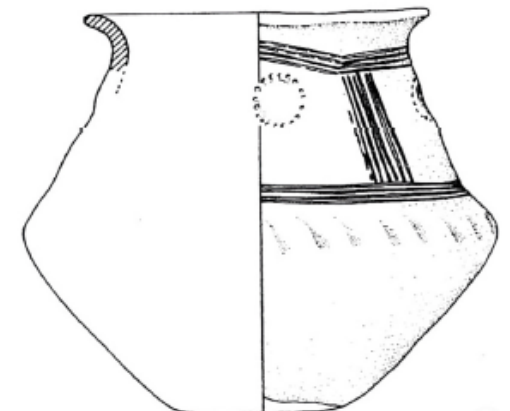
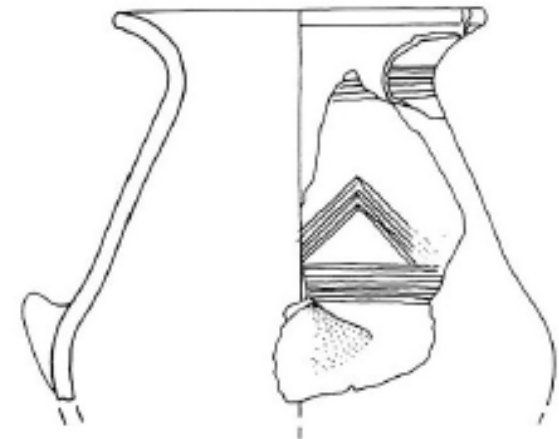

Spada a lingua da presa

Brocca a becco

Urna a collo

Struttura gerarchica di una tipologia

I **Categoria**

(PERONI 1994)



Spada a lingua da presa
con estremità a T



II **Classe**



Particolarità morfologiche e funzionali più specifiche ma ancora comuni

III a **Forma Funzionale**

III b **Foggia**

Quando le categorie della forma si associano in un dato ambiente geografico o temporale

Famiglia Tipologica

Spada da presa con estremità a T **Italiana**

Urne a collo con corpo biconico **protovillanoviane**

Urna a collo con
Corpo Biconico

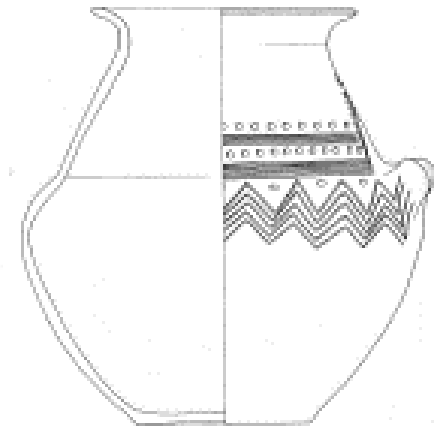
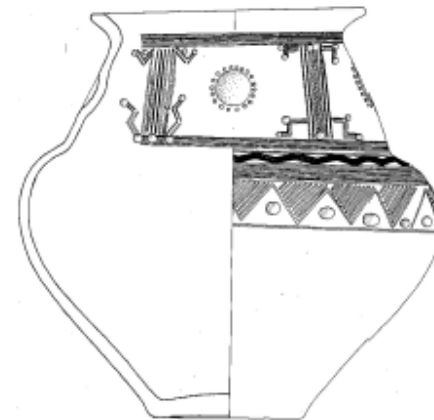
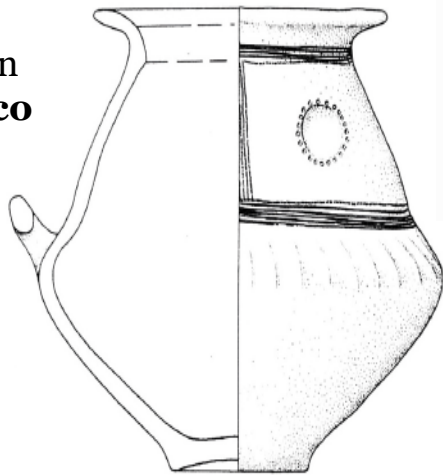
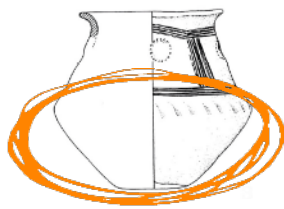

(SOTGIA 2015-2016)

Struttura gerarchica di una tipologia

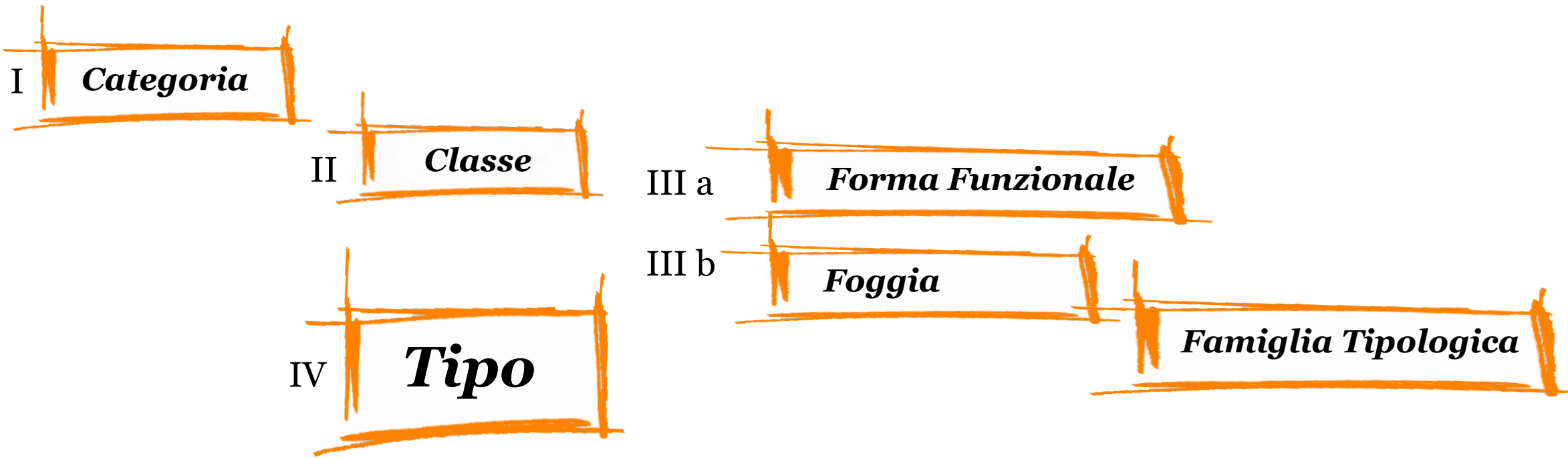

Rispondenza alla realtà più profonda di quella meramente classificatoria



Modello mentale socialmente accettato da uno o più gruppi umani



Testimoniano l'operato di soggetti storici reali

Un tipo risulta da tutti (e solo) quei reperti che sono accomunati da **specifici attributi**

Struttura gerarchica di una tipologia

I **Categoria**

II **Classe**

III a **Forma Funzionale**

III b **Foggia**

Famiglia Tipologica

IV **Tipo**

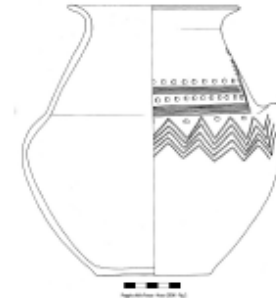
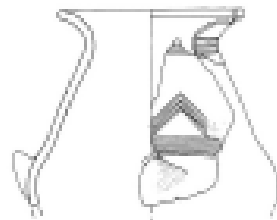
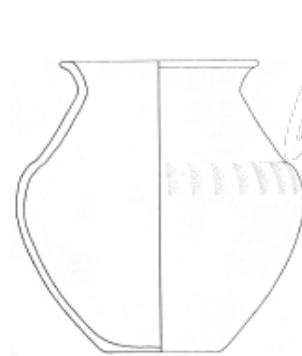
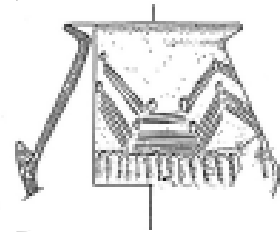

Urne Biconiche
(SOTGIA 2015-2016)



IV

Tipo

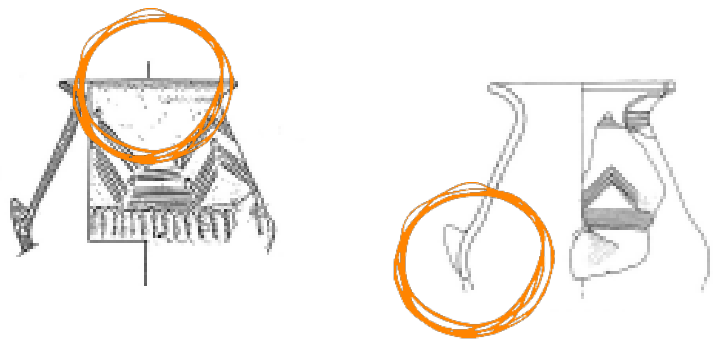
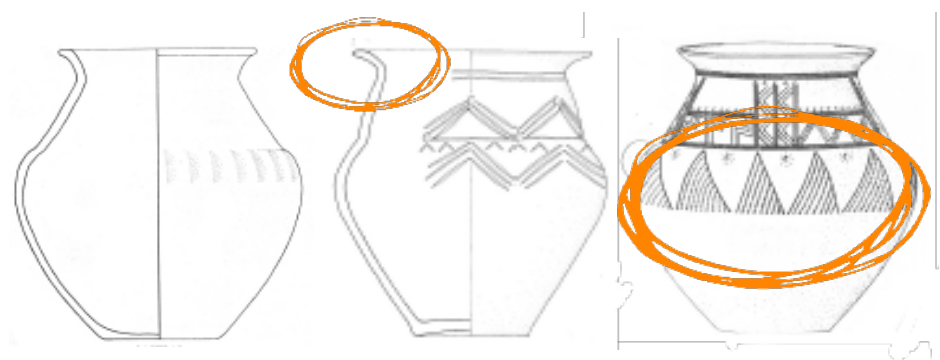

Tipo caratterizzato da:

- Spalla appena accennata
- Orlo svasato
- Imboccatura Stretta
- Alto collo troncoconico



Tipo caratterizzato da:

- Spalla accentuata
- Orlo sviluppato fortemente svasato
- Ventre arrotondato
- Collo Convesso

Urne Biconiche
(SOTGIA 2015-2016)

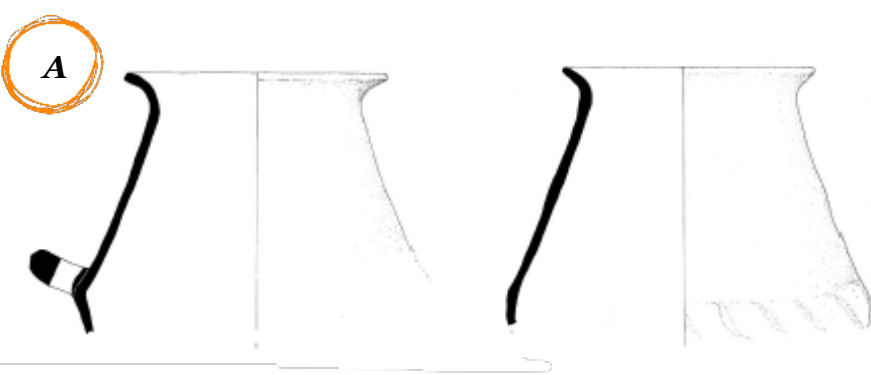

- Tipo caratterizzato da:
- Spalla appena accennata
 - Orlo svasato
 - Imboccatura Stretta
 - Alto collo troncoconico

Varietà a – Grandi dimensioni
 Varietà b – Piccole dimensioni

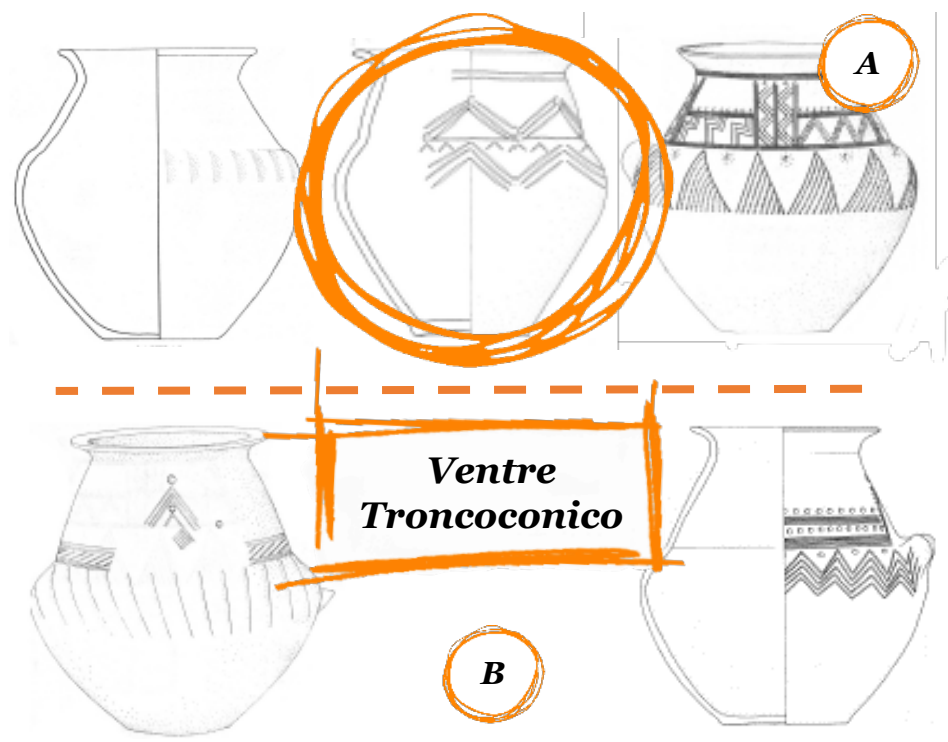
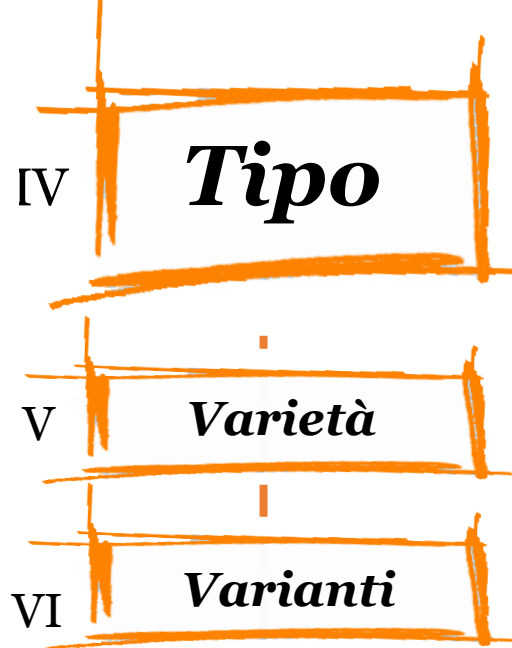

- Tipo caratterizzato da:
- Spalla accentuata
 - Orlo sviluppato fortemente svasato
 - Ventre arrotondato
 - Collo Convesso

Collo poco sviluppato – Varietà a
 Collo sviluppato – Varietà b

Urne Biconiche
 (SOTGIA 2015-2016)

I

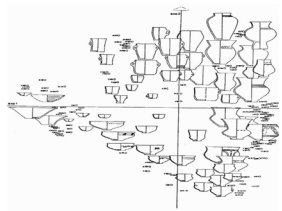

Vasi

Categoria - Regno

Animalia



II

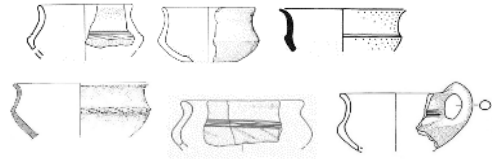

Tazze

Classe

Mammalia



III

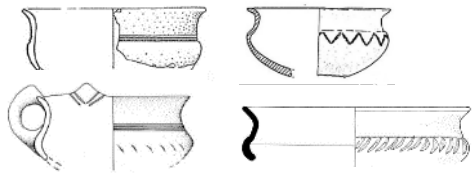

T. a Collo

Forma - Ordine

Carnivori



IV



T. a Collo
Con Costolature

Famiglia

Felidi



V



MR - 06b - 00698

Foggia - Genere

Felis

VI

Tazze a collo con costolature oblique e diametro maggiore all'orlo. Breve orlo svasato; labbro arrotondato; collo poco sviluppato rientrante spalla indistinta; vasca profonda; fondo piatto a tacco

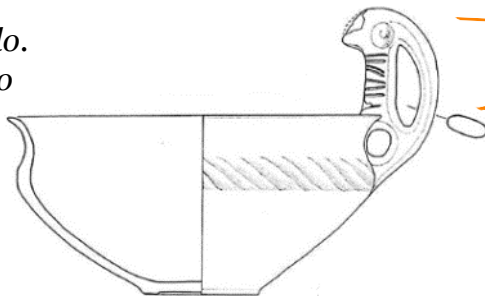

Tipo - Specie

Gatto



→ Reperti **originali e integri**

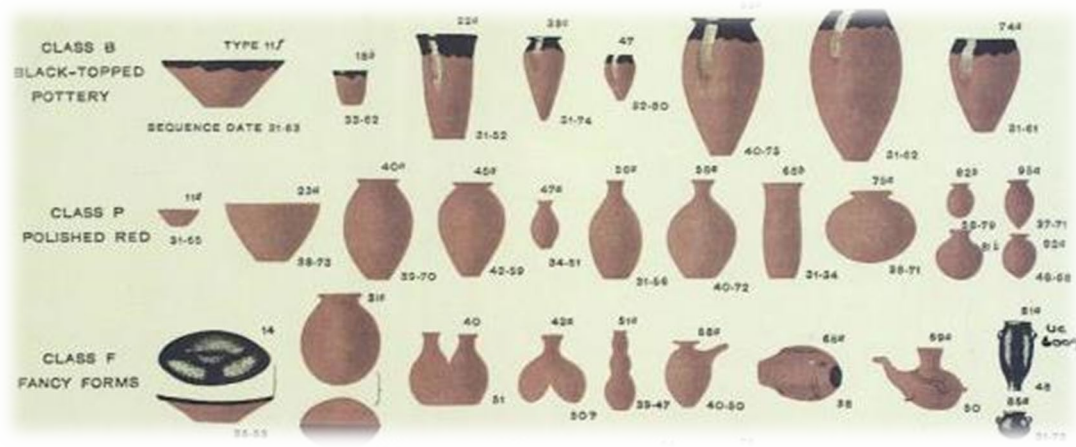

→ Descritti da un'unica persona usando un **vocabolario condiviso**

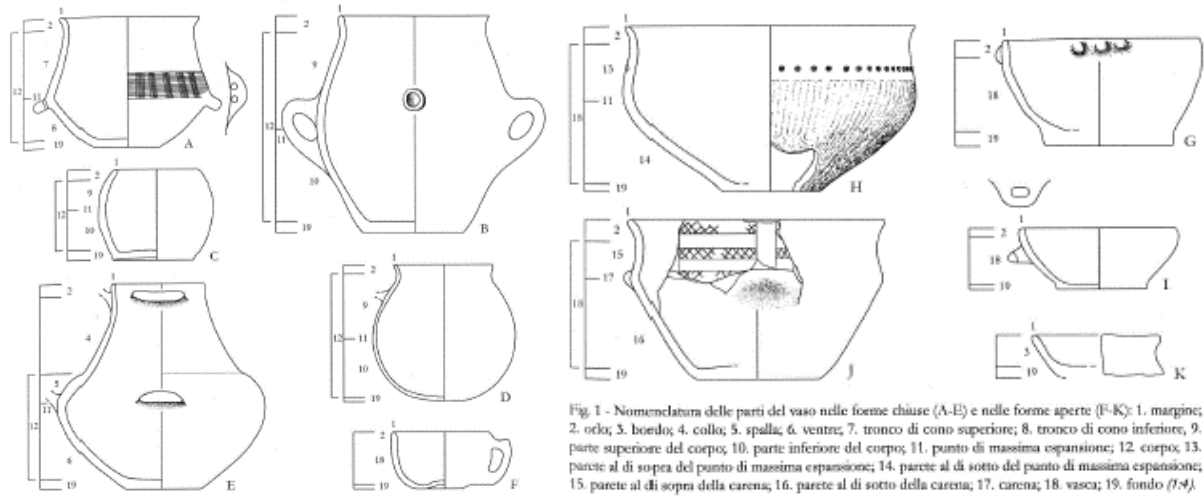
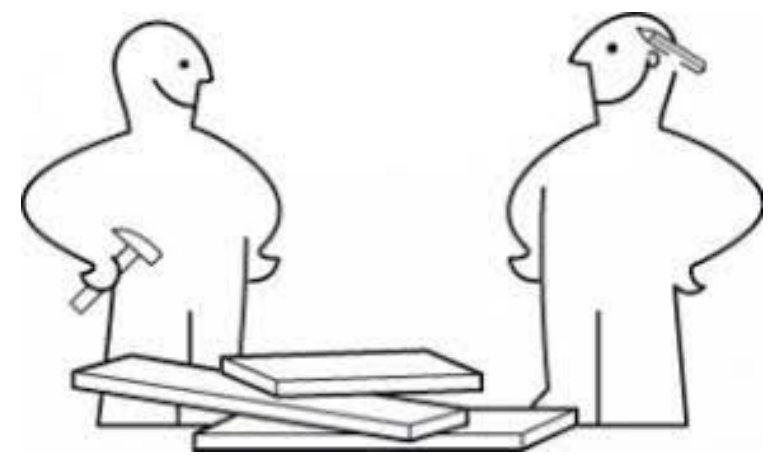
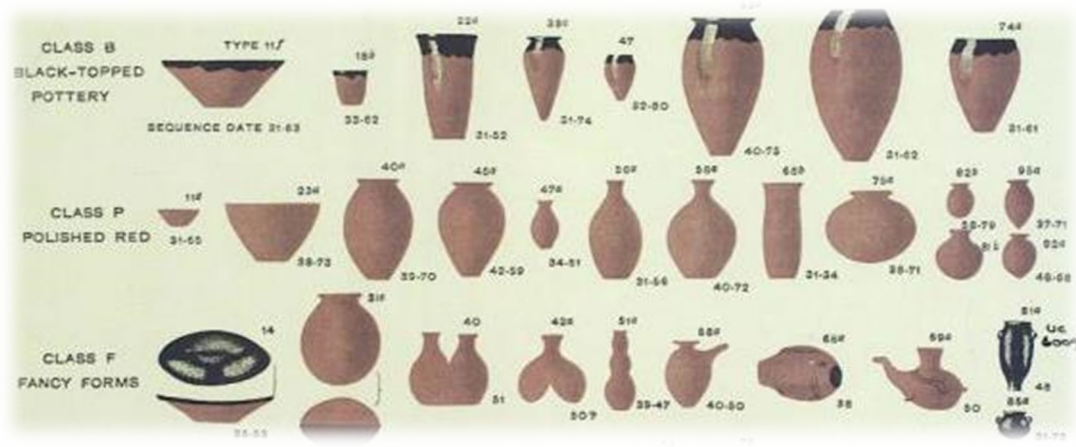

Fig. 1 - Nomenclatura delle parti del vaso nelle forme chiuse (A-E) e nelle forme aperte (F-K): 1. margine; 2. orlo; 3. boordo; 4. collo; 5. spalla; 6. ventre; 7. tronco di cono superiore; 8. tronco di cono inferiore; 9. parte superiore del corpo; 10. parte inferiore del corpo; 11. punto di massima espansione; 12. corpo; 13. parete al di sopra del punto di massima espansione; 14. parete al di sotto del punto di massima espansione; 15. parete al di sopra della carena; 16. parete al di sotto della carena; 17. carena; 18. vasca; 19. fondo (19a).

(COCCHI GENICK 2012) *Nomenclatura*



→ **Reperti originali e integri**



Frammenti!

→ **Descritti da un'unica persona usando un vocabolario condiviso**

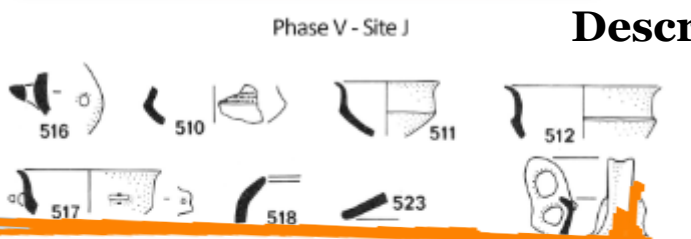

Descritti da altri!

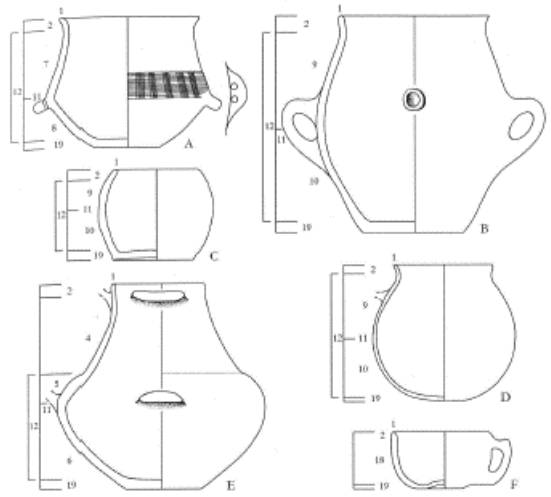

Documentazione

Terminologia

Fig. 1 - Nomenclatura delle
2. orlo; 3. bordo; 4. collo; 5. spalla; 6. ventre; 7. tronco di cono superiore; 8. tronco di cono inferiore; 9. parte superiore del corpo; 10. parte inferiore del corpo; 11. punto di massima espansione; 12. corpo; 13. parete al di sopra del punto di massima espansione; 14. parete al di sotto del punto di massima espansione; 15. parete al di sopra della carena; 16. parete al di sotto della carena; 17. carena; 18. vasca; 19. fondo (1/4).

(COCCHI GENICK 2012)

Nomenclatura

Expectations



Reality

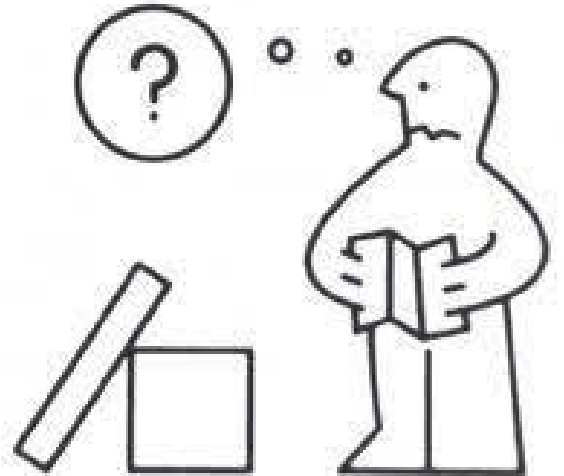

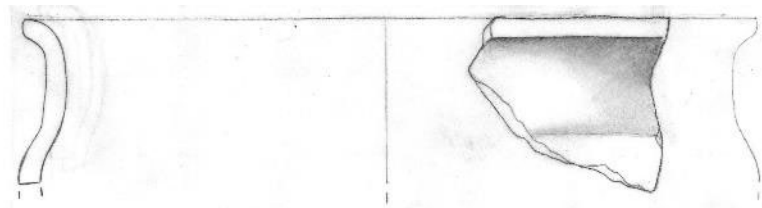
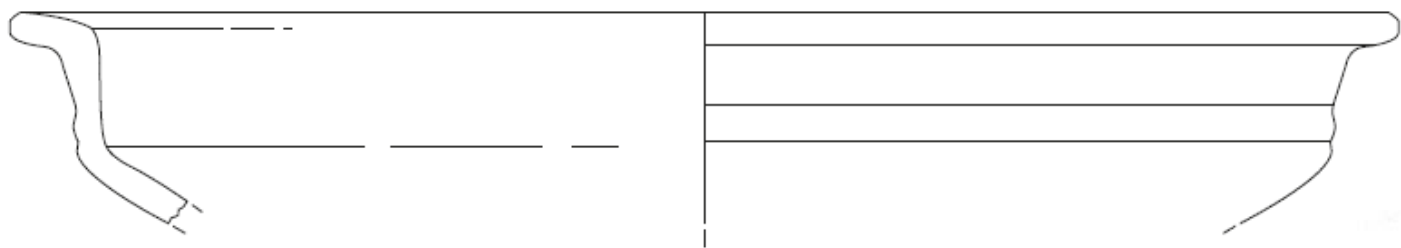
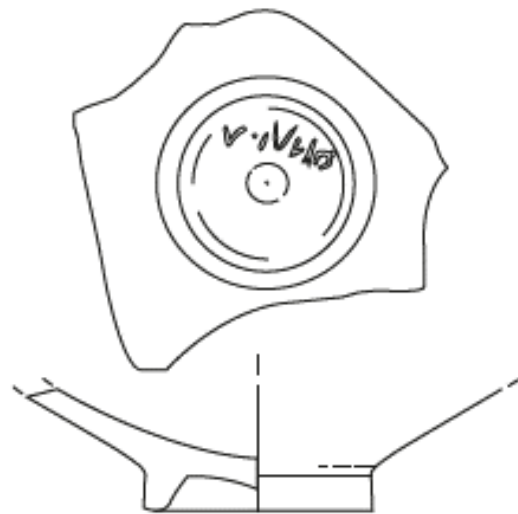
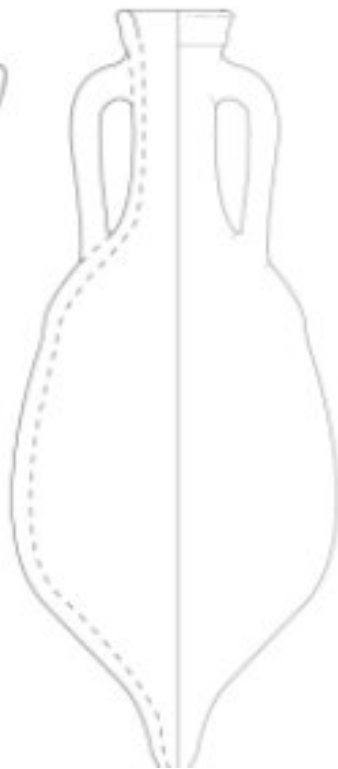
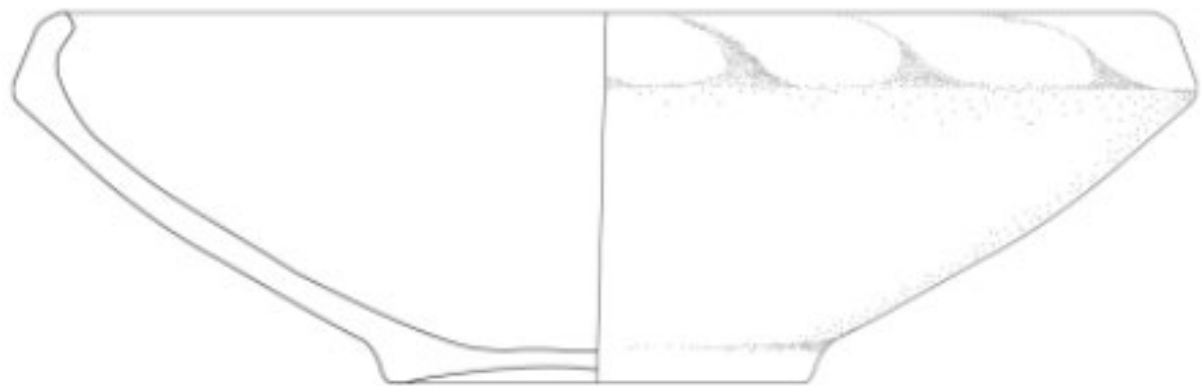

[0090]
S.M. C.
STR. 66
(R. 704)
INV. 644
DIS. 487

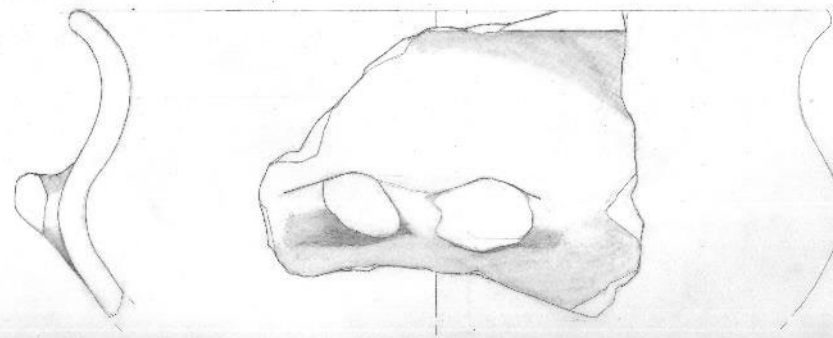
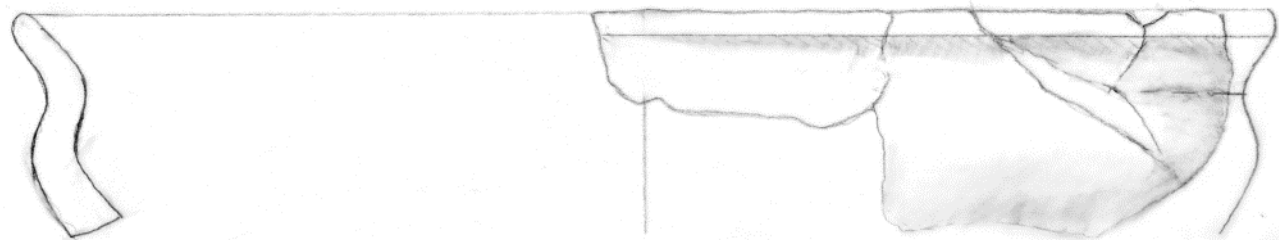

[0497]
S.M. C.
STRATO 6
(C. 704)
INV. 625
DIS. 392



Prospetto

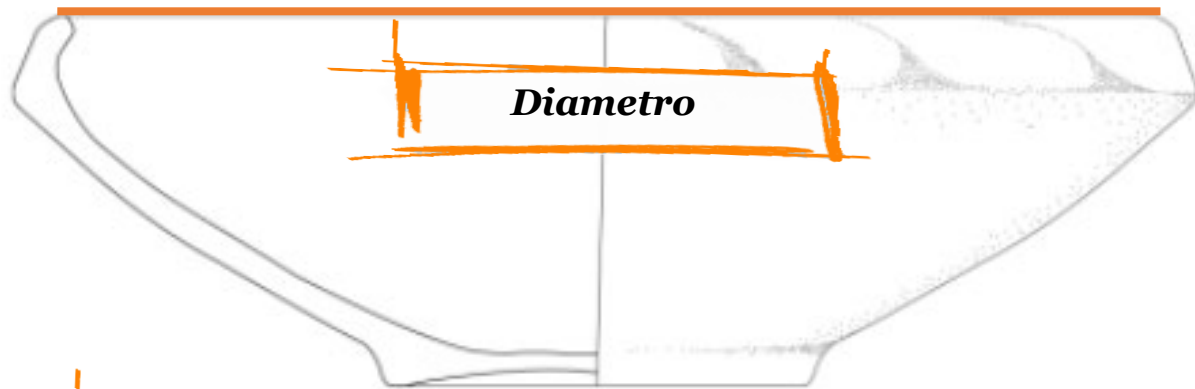

Diametro

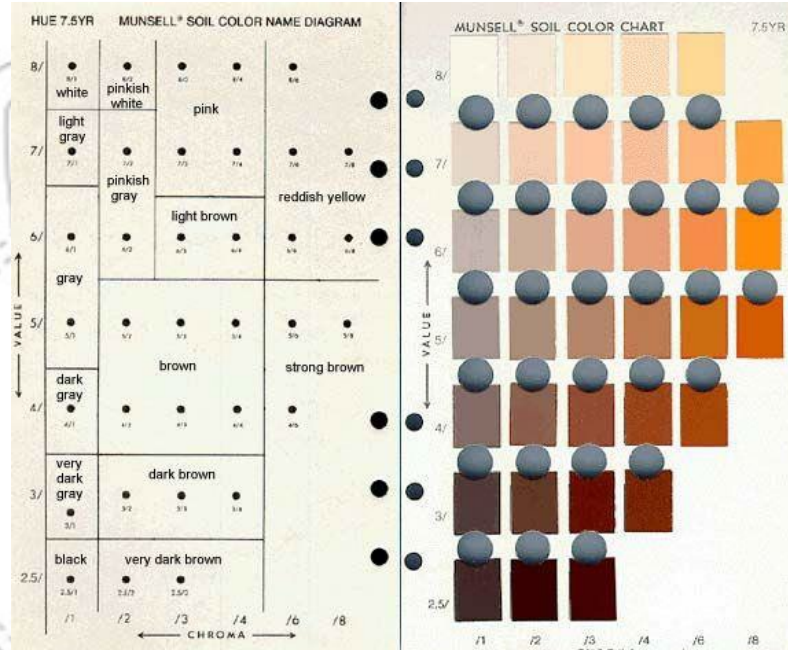

Fil di ferro



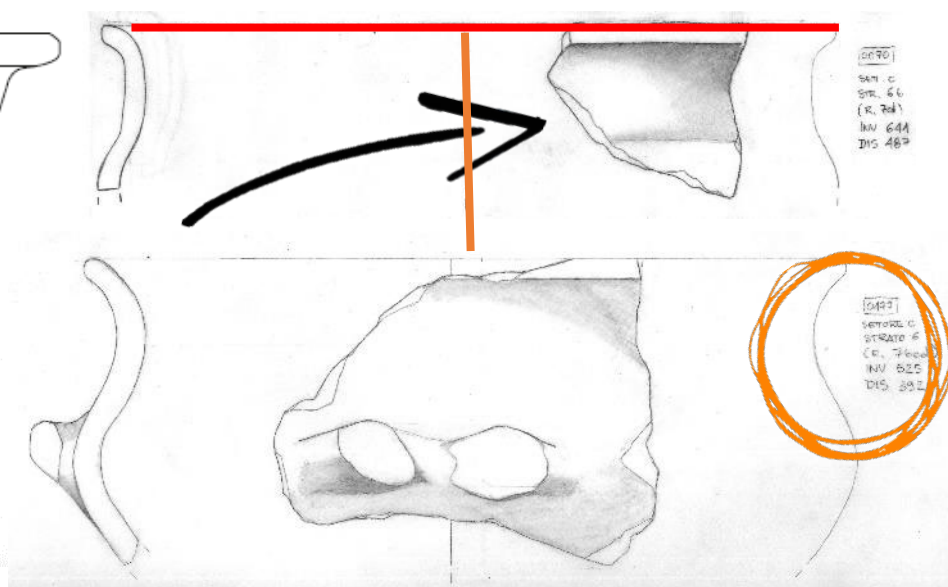

Sezione



Ombreggiato

<u>Numero Inventario</u> 00714		<u>Pacchetto</u> 0504	
<u>Settore</u>	<u>Strato</u>	<u>Riquadro</u>	<u>Frm.</u> 1
C	05	10-14-17	
			<u>Tipo</u> M31 + M14

<u>Forma</u>		<u>Misure</u>		
-		<u>Orlo</u>	<u>Parete</u>	<u>Fondo</u>
		<u>Spessore</u>	- ; 0,6 ; -	
<u>Parte</u>		<u>Diametro</u>	<u>Altezza</u> 3,3	
Parete Decorata				

<u>Disegno</u>	<u>Foto</u>
	



Descrizione

Parete decorata con fascio di solcature sormontato da fascio di solcature disposte a zig-zag marginate da impressioni a cordicella

<u>Note e Analisi</u>
<u>Note</u>
<u>Analisi</u>

<u>Materie Prime</u>			
<u>Matrice</u>	<u>Consistenza</u>	<u>Media</u>	
<u>Clasti</u>	<u>Dimensioni</u> 0,5 - 2,0	<u>Frequenza</u> 5%	
<u>Colore</u>	<input checked="" type="checkbox"/> Bianchi <input type="checkbox"/> Gialli	<u>Forma</u>	<input type="checkbox"/> Arrotondati
	<input checked="" type="checkbox"/> Trasparenti <input type="checkbox"/> Neri <input type="checkbox"/> Rossi		<input checked="" type="checkbox"/> Subarrotondati
			<input checked="" type="checkbox"/> Subangolosi <input type="checkbox"/> Angolosi
			<u>Impasto</u>
			<u>Gruppo</u>
			Fini
			<u>Sigla</u>
			1B

<u>Aspetto</u>	<u>Foggatura</u>
<u>Sfericità</u> Bassa	<u>Fratture</u>
	Orizzontali
<u>Simmetria dei Profili</u>	Orizzontali rispetto la decorazione
	Curvilinee

<u>Superfici & Cottura</u>			
<u>Esterno</u>	<u>Colore</u>	<u>Uniformità</u>	
	Dull Orange Hue 7.5 YR 4 7	Omogeneo	
<u>Trattamento</u>	Lisciata	<input type="checkbox"/> Abrasioni	<input type="checkbox"/> Bruciature
<u>Copertura</u>	Totale	<input type="checkbox"/> Scheggiature	<input type="checkbox"/> Incrostazioni
<u>Interno</u>	<u>Colore</u>	<u>Uniformità</u>	
	Dull Orange Hue 7.5 YR 3 7	Omogeneo	
<u>Trattamento</u>	Lisciata	<input type="checkbox"/> Abrasioni	<input type="checkbox"/> Bruciature
<u>Copertura</u>	Totale	<input type="checkbox"/> Scheggiature	<input type="checkbox"/> Incrostazioni
		<input type="checkbox"/> Striature	

Sezione

Cuore Nero

Dull Orange
Hue 7.5 YR 4 7



Confronti

Decorazione

Tecnica Decorazione

Combinazione di tecniche differenti

Motivo Decorativo

Descrizione

Tipo: M31 + M14



giato

0070
SAM C
STR. 66
(R. 704)
INV. 644
DIS. 48P

0071
SETORE C
STRATO 6
(C. 704)
INV. 625
DIS. 382

Non esiste una regola su quali caratteristiche utilizzare e in quale ordine
MA .. E' importante comunicare **il perché delle scelte compiute**

Approccio

- Etico

Osservare in maniera **oggettiva**

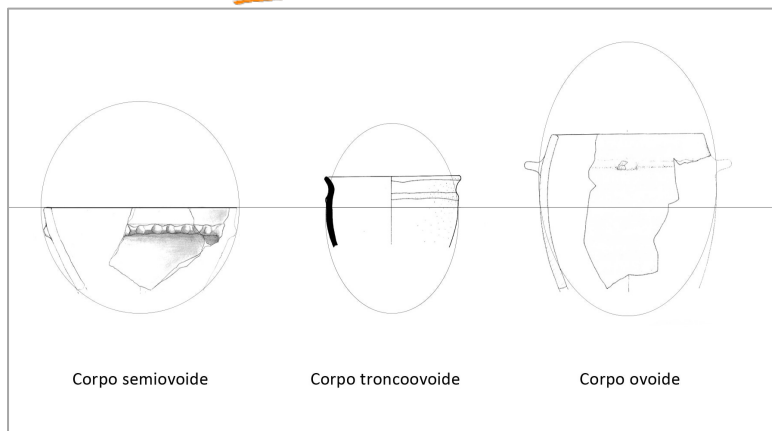

SOTGIA 2015-2016

Approccio

- Emico

Utilizza quanto detto da un **informatore**

fonti scritte

Classificazione



JONES ET. AL 2014

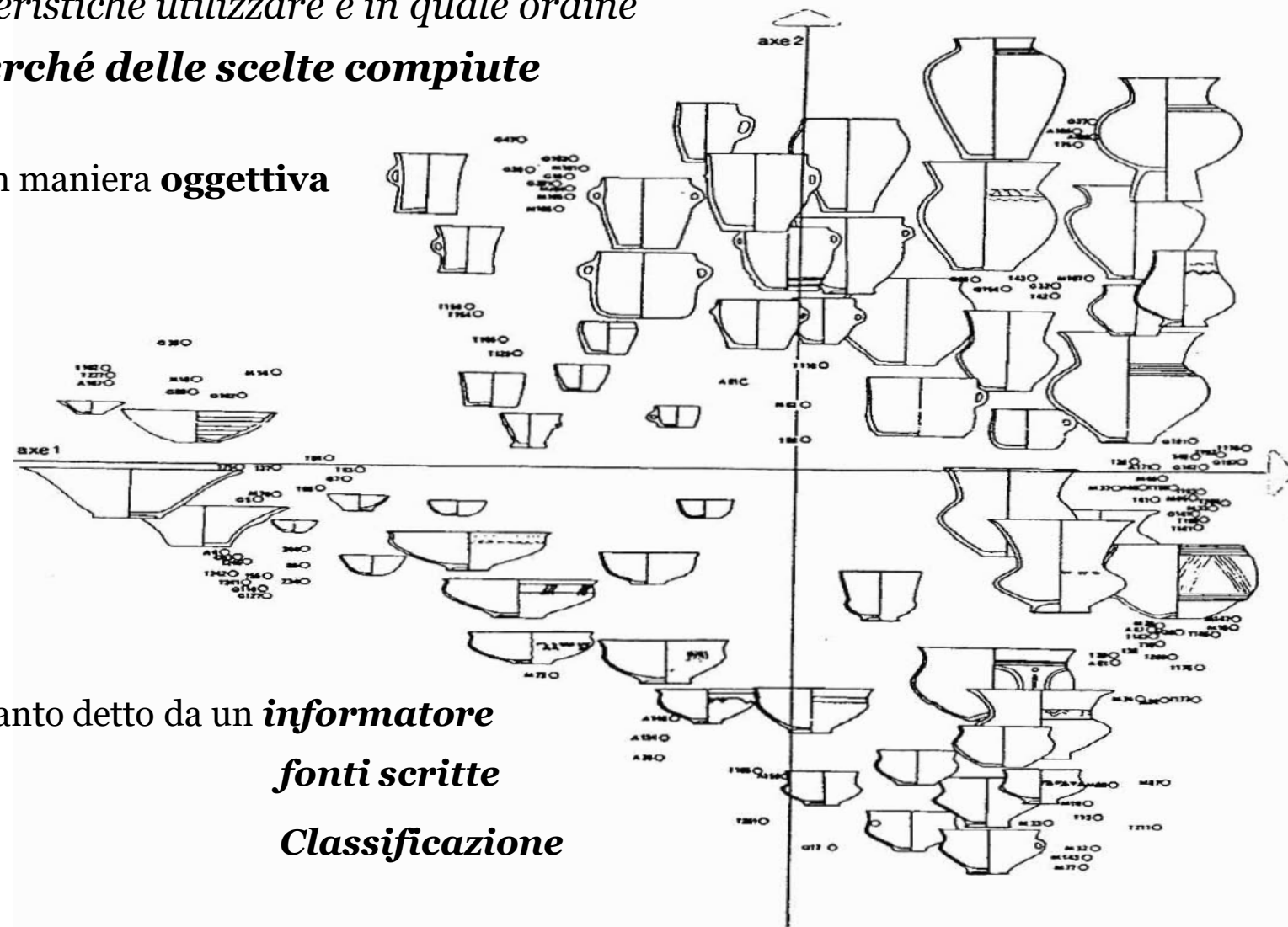

« Grazie all'individuazione dei tipi – veicoli fossili di informazione – è possibile stabilire un rapporto non mediato con le comunità antiche »

PERONI 1998



« sarebbe preferibile adottare un sistema tipologico il più possibile simile ai criteri adottati dalle comunità antiche in relazione alle diverse produzioni, ma spesso non è possibile per vari ordini di motivi [...] »

(CARDARELLI 2014)

« nella prassi ogni classificazione deve misurarsi con l'obiettivo per cui viene realizzata [...] »

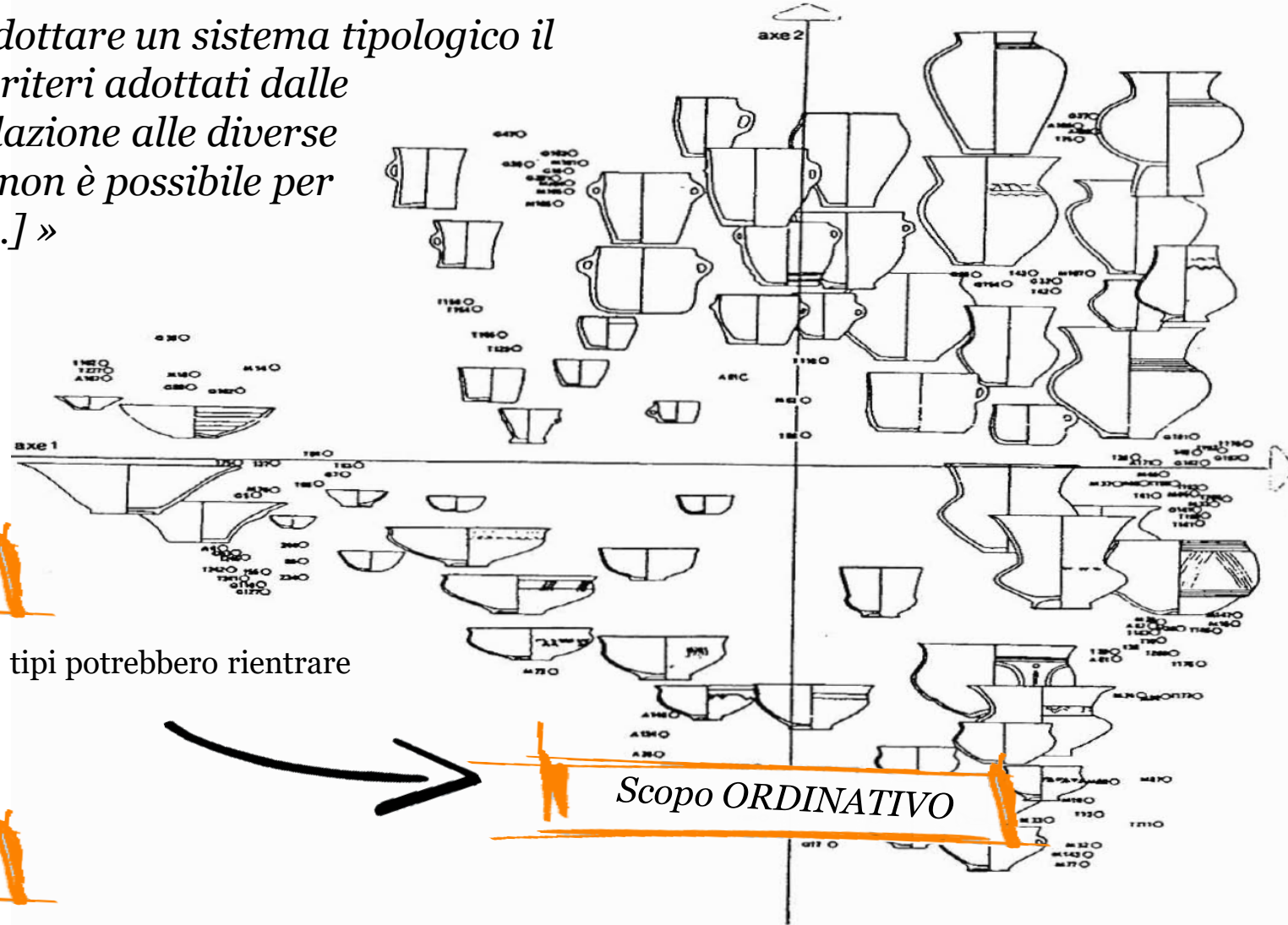

Tipologia

a maglie larghe

il livello di dettaglio non è minuziosissimo e nei tipi potrebbero rientrare assieme modelli formali o stilistici diversi.

Tipologia

a maglie strette

il livello di dettagli è minuziosissimo e potrebbe accadere che esemplari derivanti da un comune modello potrebbero finire in tipi diversi

Scopo ORDINATIVO

Scopo CRONOLOGICO

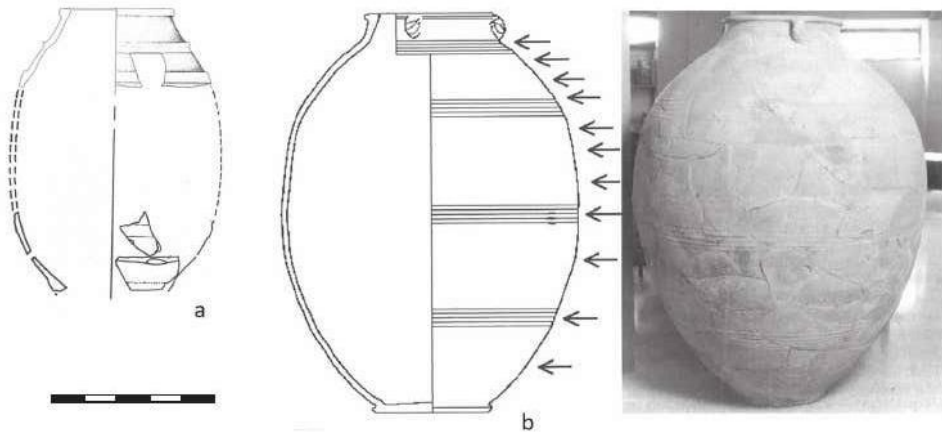

(PORTA 2021)



(PORTA 2014)

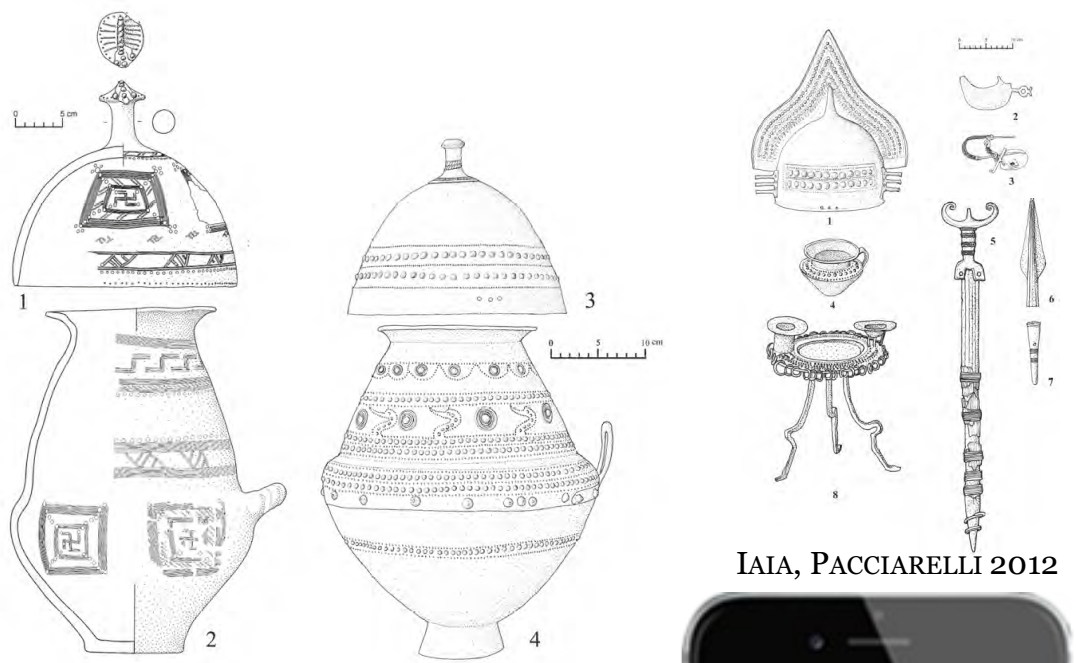

IAIA, PACCIARELLI 2012

Tipologia dell'IPhone





(PORTA 2021)

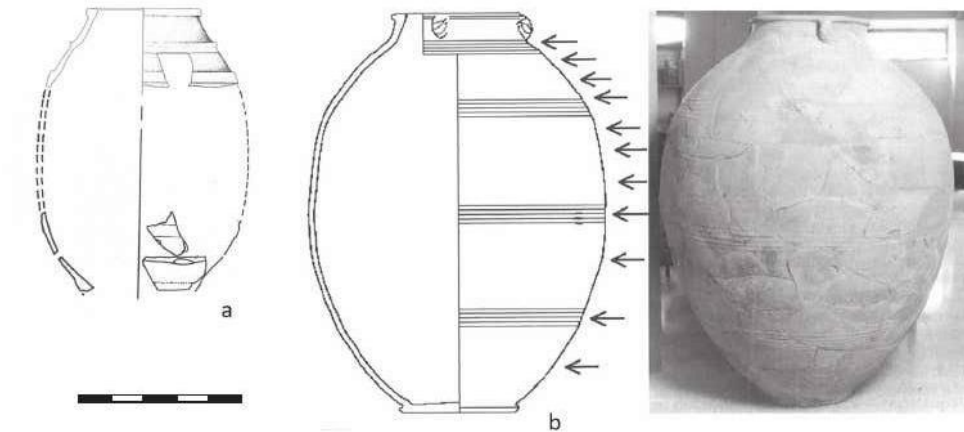

(PORTA 2014)

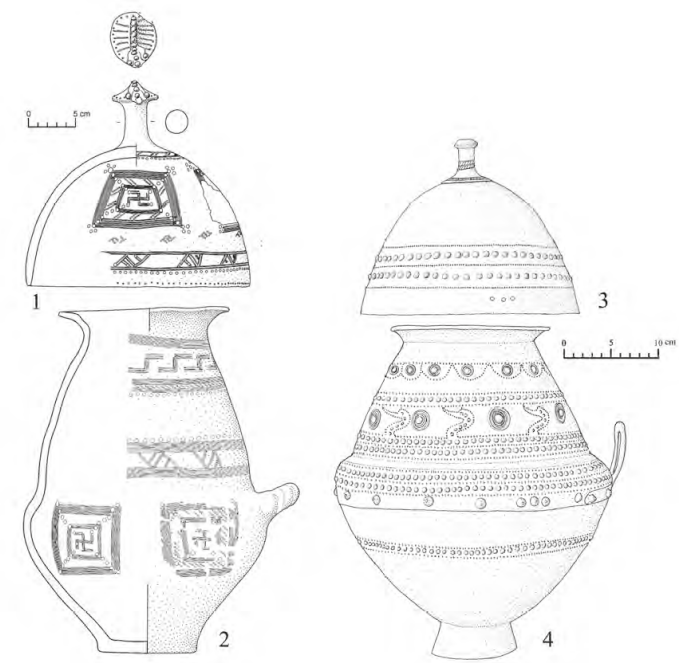

IAIA, PACCIARELLI 2012

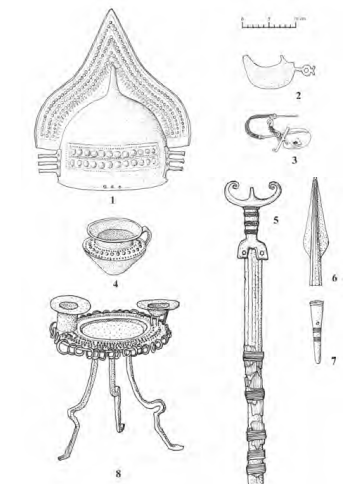

Tipologia dell'IPhone



« Il bravo storico, invece, somiglia all'orco della fiaba. Egli sa che là dove fiuta carne umana , là è la sua preda »

(BLOCH 1949)

Un po' di bibliografia

- L. BINFORD, *Archaeology as Anthropology*, in *American Antiquity* Vol. 28 (1962) pp. 217-225
- A. CARANDINI, *Archeologia e Cultura Materiale*, 1979
- A. CARDARELLI, *La necropoli della terramara di Casinalbo*, 2014 (Capitolo 3)
- D. COCCHI GENICK, *Le potenzialità informative delle ceramiche nell'analisi storica*, 2012 (Capitolo 1)
- R. PERONI, *Introduzione alla Protostoria Italiana*, 1994
- R. PERONI, *Classificazione Tipologica, Seriazione Cronologia, Distribuzione Geografica* in *Aquileia Nostra LXIX* (1998), pp. 9-28
- M. VIDALE, *Ceramica e Archeologia*, 2007

- A. SOTGIA, *Fornaci per ceramica ed aree produttive in Italia tra Età del Bronzo ed Età del Ferro*, in *IpoTESI diPreistoria 12* (2019) pp. 301-318
- A. SOTGIA, *I Vasai della Montana. Tracciare le "communities of practice" dei Monti della Tolfa attraverso analisi territoriali*, in M. GNADE & M. REVELLO LAMI (eds.) *Tracing Technology*, 2020, pp. 255-263
- M. REVELLO LAMI, *Disegnare per Osservare, Capire, Raccontare. Conversazione con Agostino Sotgia* in *Ex-Novo Journal of Archaeology* 6 (2021), pp. 217-222

La Classificazione Tipologica ...

*... Coordinate Teoriche,
Consigli Pratici &
Trucchi
per affrontarla
al meglio !*



Agostino Sotgia
agostino.sotgia@uniroma1.it
Sapienza – Università di Roma
RUG - University of Groningen



Seminario di 20 ore per il corso di studi in Lettere, Arte, Archeologia (L-10)

Metodi e Pratiche di Studio della Cultura Materiale
oggetti, contesti e storie per conoscere il territorio

24-05-2022

Università di Ferrara